

# **SEARS**

## **OWNER'S MANUAL**

### **MODEL NO. 536.886331**

### **HOW TO ORDER REPAIR PARTS**

# **CRAFTSMAN®**

## **10 HORSEPOWER 29" DUAL STAGE 120V. ELECTRIC START SNOW THROWER**

**WHEN ORDERING REPAIR PARTS, ALWAYS**

Each SNOW THROWER has its own MODEL NUMBER found on the engine mount frame.

Each ENGINE has its own MODEL NUMBER found on the BLOWER HOUSING.

Always mention these MODEL NUMBERS when requesting service or Repair Parts for your SNOW THROWER.

All parts may be ordered through Sears, Roebuck and Company Service Centers and most Retail Stores.

**GIVE THE FOLLOWING INFORMATION:**

- \* PRODUCT - "SNOW THROWER"
- \* MODEL NUMBER - 536.886331
- \* ENGINE MODEL NUMBER - 143.941001
- \* PART NUMBER
- \* PART DESCRIPTION

"Your Sears merchandise has added value when you consider that Sears has service units nationwide staffed with Sears trained technicians...Professional technicians specifically trained on Sears products, having the parts, tools and equipment to ensure that we meet our pledge to you...we service what we sell."

**SEARS, ROEBUCK AND CO., Hoffman Estates, IL 60179**

## SAFETY RULES



**CAUTION: ALWAYS DISCONNECT SPARK PLUG WIRE AND PLACE WIRE WHERE IT CANNOT CONTACT SPARK PLUG TO PREVENT ACCIDENTAL STARTING WHEN SETTING-UP TRANSPORTING, ADJUSTING OR MAKING REPAIRS.**



### IMPORTANT

SAFETY STANDARDS REQUIRE OPERATOR PRESENCE CONTROLS TO MINIMIZE THE RISK OF INJURY. YOUR SNOW THROWER IS EQUIPPED WITH SUCH CONTROLS. DO NOT ATTEMPT TO DEFEAT THE FUNCTION OF THE OPERATOR PRESENCE CONTROL UNDER ANY CIRCUMSTANCES.

#### BEFORE USE

- Read the Owner's Manual carefully. Be thoroughly familiar with the controls and the proper use of the snow thrower. Know how to stop the snow thrower and disengage the controls quickly.
- Do not operate the snow thrower without wearing adequate winter outer garments. Wear footwear that will improve footing on slippery surfaces.
- Keep the area of operation clear of all persons, particularly small children, and pets.
- Thoroughly inspect the area where the snow thrower is to be used and remove all doormats, sleds, boards, wires, and other foreign objects.
- Use extension cords and receptacles as specified by the manufacturer for all snow throwers with electric drive motors or with factory-installed or optional starting motors.
- Use only attachments and accessories approved by the manufacturer of the snow thrower (such as electric starter kits, etc.).
- Never operate the snow thrower without good visibility or light. Always be sure of your footing, and keep a firm hold on the handles. Walk; never run.
- This snow thrower is for use on sidewalks, driveways, and other ground level surfaces. CAUTION should be exercised while using on steep sloping surfaces. DO NOT USE SNOW THROWER ON SURFACES ABOVE GROUND LEVEL such as roofs of residences, garages, porches or other such structures or buildings.
- Check all bolts at frequent intervals for proper tightness to be sure the snow thrower is in safe working condition.
- Disengage clutch before starting the engine.
- Let engine and snow thrower adjust to outdoor temperatures before starting to clear snow.

#### FUEL SAFETY

- Handle fuel with care; it is highly flammable.
- Use an approved fuel container.
- Check fuel supply before each use, allowing space for expansion as the heat of the engine and/or sun can cause fuel to expand.
- Fill fuel tank outdoors with extreme care. Never fill fuel tank indoors.
- Replace fuel tank cap securely and wipe up spilled fuel.
- Never remove fuel tank cap or add fuel to a running engine or hot engine.
- Never store fuel or snow thrower with fuel in the tank inside a building where fumes may reach an open flame or spark.

#### OPERATING SAFETY

- Never allow children or young teenagers to operate the snow thrower and keep them away while it is operating. Never allow adults to operate the snow thrower without proper instruction. Do not carry passengers.
- Always wear safety glasses or eye shields during operation or while performing an adjustment or repair to protect eyes from foreign objects that may be thrown from the snow thrower.
- Exercise extreme caution when operating on or crossing gravel drives, walks, or roads. Stay alert for hidden hazards or traffic.
- Do not put hands or feet near or under rotating parts. Keep clear of the discharge opening at all times.
- Exercise caution to avoid slipping or falling, especially when operating in reverse or backing up.
- Do not clear snow across the face of slopes. Exercise caution when changing direction on slopes. Do not attempt to clear steep slopes.
- Never operate the snow thrower without proper guards, plates or other safety protective devices in place.

## SAFETY RULES

- Never operate the snow thrower near glass enclosures, automobiles, window wells drop-offs, and the like without proper adjustment of the snow discharge angle. Keep children and pets away.
- Never operate the snow thrower at high transport speeds on slippery surfaces. Look behind and use care when backing.
- Never direct discharge at bystanders or allow anyone in front of the snow thrower.
- Do not run the engine indoors, except when starting the engine and for transporting the snow thrower in or out of the building. Open the outside doors; exhaust fumes are dangerous (containing CARBON MONOXIDE, an ODORLESS and DEADLY GAS).
- Take all possible precautions when leaving the snow thrower unattended. Disengage the auger/impeller, stop engine, and remove key.
- Do not overload the machine capacity by attempting to clear snow at too fast a rate.

### SAFE STORAGE

- Always refer to Owner's Manual instructions for important details if the snow thrower is to be stored for an extended period.
- Disengage power to the auger/impeller when snow thrower is transported or not in use.
- Never store the snow thrower with fuel in the fuel tank inside a building where ignition sources are present such as hot water and space heaters, clothes dryers, and the like. Allow the engine to cool before storing in any enclosure.

### REPAIR/ADJUSTMENTS SAFETY

- After striking a foreign object, stop the engine and remove the wire from the spark plug, or disconnect the cord from electric motor. Thoroughly inspect the snow thrower for any damage, and repair the damage before restarting and operating the snow thrower.
- If the snow thrower should start to vibrate abnormally, stop the engine (or electric motor) and check immediately for the cause. Vibration is generally a warning of trouble.
- Stop the engine (or electric motor) whenever you leave the operating position, before unclogging the auger/impeller housing or discharge guide, and when making any repairs, adjustments, or inspections. Remove wire from spark plug or disconnect cord from electric motor.
- When cleaning, repairing, or inspecting, make certain the auger/impeller and all moving parts have stopped. Disconnect the spark plug wire and keep the wire away from the plug to prevent accidental starting.
- Never attempt to make any adjustments while the engine is running (except when specifically recommended in this manual).
- Maintain or replace safety and instruction labels, as necessary.
- Run the snow thrower a few minutes after throwing snow to prevent freeze-up of the auger/impeller.

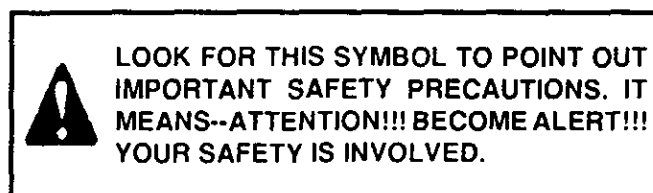

**CONGRATULATIONS** on your purchase of a Sears Craftsman Snow Thrower. It has been designed, engineered and manufactured to give you the best possible dependability and performance.

Should you experience any problem you cannot easily remedy, please contact your nearest Sears Service Center/Department. Sears has competent, well-trained technicians and the proper tools to service or repair this unit.

Please read and retain this manual. The instructions will enable you to assemble and maintain your snow thrower properly. Always observe the "SAFETY RULES."

MODEL  
NUMBER 536.886331

SERIAL  
NUMBER \_\_\_\_\_

DATE OF  
PURCHASE \_\_\_\_\_

THE MODEL AND SERIAL NUMBERS WILL BE FOUND ON A DECAL ATTACHED TO THE REAR OF THE SNOW THROWER HOUSING.

YOU SHOULD RECORD BOTH SERIAL NUMBER AND DATE OF PURCHASE AND KEEP IN A SAFE PLACE FOR FUTURE REFERENCE.

## PRODUCT SPECIFICATIONS

<b>HORSE POWER:</b>	<b>10 hp</b>
<b>DISPLACEMENT:</b>	<b>21.82 cu. in.</b>
<b>GASOLINE CAPACITY:</b>	<b>4 quarts Unleaded</b>
<b>OIL (26 oz. Capacity):</b>	<b>5W - 30</b>
<b>SPARK PLUG : (GAP .030 In.)</b>	<b>Champion RJ19LM</b>
<b>VALVE CLEARANCE:</b>	<b>Intake: .010 In. Exhaust: .010 In.</b>

## MAINTENANCE AGREEMENT

Sears Maintenance Agreement is available on this product. Contact your nearest Sears Store for details.

## CUSTOMER RESPONSIBILITIES

Read and observe the safety rules.

Follow a regular schedule in maintaining, caring for and using your snow thrower.

Follow the instructions under "Customer Responsibilities" and "Storage" sections of this owner's manual.

## TWO YEAR LIMITED WARRANTY ON CRAFTSMAN SNOW THROWER

For two years from the date of purchase, when this Craftsman Snow Thrower is maintained, lubricated and tuned-up according to the instructions in the owner's manual, Sears will repair, free of charge, any defect in material and workmanship.

If this Craftsman Snow Thrower is used for commercial or rental purposes, this warranty applies for only 90 days from the date of purchase.

This warranty does not cover the following:

- Expendable items which become worn during normal use, such as spark plugs, drive belts and shear pins.
- Repairs necessary because of operator abuse or negligence, including bent crankshafts and the failure to maintain the equipment according to the instructions contained in the owner's manual.

WARRANTY SERVICE IS AVAILABLE BY RETURNING THE CRAFTSMAN SNOW THROWER TO THE NEAREST SEARS SERVICE CENTER/DEPARTMENT IN THE UNITED STATES. THIS WARRANTY APPLIES ONLY WHILE THIS PRODUCT IS IN USE IN THE UNITED STATES.

This warranty gives you specific legal rights, and you may also have other rights which may vary from state to state.

SEARS, ROEBUCK AND CO. Department D/817WA, Hoffman Estates, IL 60179

## TABLE OF CONTENTS

SAFETY RULES .....	2,3	OPERATION .....	11-16
PRODUCT SPECIFICATIONS .....	4	SERVICE AND ADJUSTMENTS .....	20-26
CUSTOMER RESPONSIBILITIES .....	4,17-19	STORAGE .....	27
WARRANTY .....	4	TROUBLE SHOOTING .....	28
TABLE OF CONTENTS .....	5	REPAIR PARTS (SNOW THROWER) .....	29-40
INDEX .....	5	REPAIR PARTS (ENGINE) .....	41-45
ASSEMBLY .....	6-10	PARTS ORDERING/SERVICE .....	48

## INDEX

<p><b>A</b></p> <p>Adjustment:</p> <ul style="list-style-type: none"> <li>Auger ..... 21</li> <li>Belt ..... 21</li> <li>Belt Guide ..... 23</li> <li>Cable ..... 21</li> <li>Carburetor ..... 26</li> <li>Friction Wheel ..... 23</li> <li>Spark Plug ..... 25</li> <li>Traction and Auger ..... 21</li> </ul> <p>Assembly:</p> <ul style="list-style-type: none"> <li>Check List ..... 10</li> <li>Control Cables ..... 9</li> <li>Crank Assembly ..... 8</li> <li>Headlight ..... 9</li> <li>Shifter Lever and Shifter Knob ..... 10</li> <li>Skid Height Adjustment ..... 7, 20</li> <li>Snow Chute ..... 8</li> <li>Unpacking ..... 7</li> </ul> <p><b>B</b></p> <p>Belts:</p> <ul style="list-style-type: none"> <li>Adjust Belts ..... 21</li> <li>Belt Guide Adjustment ..... 23</li> <li>Belt Maintenance ..... 18</li> <li>Replace Belts ..... 22, 23</li> </ul> <p><b>C</b></p> <ul style="list-style-type: none"> <li>Cables, Clutch ..... 9, 10, 21</li> <li>Carburetor: ..... 25</li> <li>Choke ..... 11, 12, 14, 15, 16</li> <li>Clutch, Levers ..... 11, 12</li> <li>Controls: <ul style="list-style-type: none"> <li>Engine ..... 11, 12, 14, 15</li> <li>Snow Thrower ..... 11</li> </ul> </li> <li>Crank: <ul style="list-style-type: none"> <li>Adjusting Rod ..... 8, 20</li> <li>Assembly ..... 8</li> <li>Operation ..... 12</li> </ul> </li> <li>Customer Responsibilities ..... 4, 17-19 <ul style="list-style-type: none"> <li>Agreement ..... 4</li> <li>Auger Gear Box ..... 18</li> <li>Auger Shaft ..... 18</li> <li>Engine ..... 19</li> <li>General Recommendations ..... 18</li> <li>Hex Shaft and Gears ..... 18</li> <li>Spark Plug ..... 19</li> </ul> </li> </ul> <p><b>D</b></p> <ul style="list-style-type: none"> <li>Drive, Auger ..... 12</li> <li>Drive, Traction ..... 12</li> <li>Deflector, Snow Chute ..... 12</li> </ul> <p><b>E</b></p> <p>Engine:</p> <ul style="list-style-type: none"> <li>Control ..... 10, 11, 13, 14, 15</li> </ul>	<ul style="list-style-type: none"> <li>Oil Cap ..... 13, 19</li> <li>Oil Change ..... 19</li> <li>Oil Level ..... 13, 19</li> <li>Oil Type ..... 4, 13, 19</li> <li>Speed Governor ..... 25</li> <li>Starting, Electrically ..... 14</li> <li>Starting, Manually ..... 16</li> <li>Storage ..... 27</li> </ul> <p><b>F</b></p> <ul style="list-style-type: none"> <li>Fuel, Type ..... 4, 13</li> <li>Fuel, Storage ..... 13, 27</li> <li>Friction Wheel: <ul style="list-style-type: none"> <li>Adjustment ..... 23</li> <li>Replacement ..... 24</li> </ul> </li> </ul> <p><b>G</b></p> <p>Gears:</p> <ul style="list-style-type: none"> <li>Auger Gear Box ..... 18, 19</li> <li>Hex Shaft ..... 18</li> </ul> <p><b>H</b></p> <ul style="list-style-type: none"> <li>Handle, Upper and Lower ..... 8</li> <li>Headlight ..... 9</li> <li>Height Adjust Skids ..... 7, 20</li> <li>Hex Shaft ..... 18, 19</li> </ul> <p><b>I</b></p> <ul style="list-style-type: none"> <li>Ignition, Key ..... 10, 11, 13, 14</li> <li>Index ..... 5</li> </ul> <p><b>L</b></p> <p>Levers:</p> <ul style="list-style-type: none"> <li>Auger Drive Clutch ..... 9, 11, 12, 21</li> <li>Choke ..... 11, 12, 14, 15</li> <li>Shifter ..... 10, 12</li> <li>Throttle Control ..... 11, 12, 14, 15</li> <li>Traction Drive Clutch ..... 9, 11, 12, 21</li> </ul> <p>Lubrication:</p> <ul style="list-style-type: none"> <li>Auger Gear Box ..... 19</li> <li>Auger Shaft ..... 17, 18</li> <li>Chain and Sprockets ..... 17, 18</li> <li>Chart ..... 17</li> <li>Disc Drive Plate ..... 19</li> <li>Engine ..... 13, 19</li> <li>Hex Shaft and Gears ..... 19</li> <li>Weight Transfer System ..... 18</li> </ul> <p><b>O</b></p> <p>Oil:</p> <ul style="list-style-type: none"> <li>Engine ..... 4, 13, 19</li> <li>Extreme Cold Weather ..... 13, 19</li> <li>Storage ..... 27</li> <li>Type ..... 4, 13, 19</li> </ul> <p>Operation:</p> <ul style="list-style-type: none"> <li>Engine Controls ..... 11, 12, 14, 15</li> <li>Operating Snow Thrower ... 12, 13, 16</li> <li>Operating Tips ..... 16</li> </ul>	<ul style="list-style-type: none"> <li>Starting the Engine, Electric ..... 14</li> <li>Starting the Engine, Recoil ..... 15, 16</li> <li>Snow Thrower Controls ..... 11-13</li> </ul> <p><b>P</b></p> <ul style="list-style-type: none"> <li>Parts ..... 29-40</li> <li>Primer Button ..... 11, 12, 14, 15</li> </ul> <p><b>R</b></p> <ul style="list-style-type: none"> <li>Repair/Replacement Parts ..... 29-40</li> <li>Recoil Starter ..... 15, 16</li> <li>Replacements: <ul style="list-style-type: none"> <li>Auger Shear Bolt ..... 25</li> <li>Belts ..... 22, 23</li> <li>Friction Wheel ..... 24</li> </ul> </li> </ul> <p><b>S</b></p> <ul style="list-style-type: none"> <li>Safety Rules ..... 2, 3</li> <li>Service and Adjustments: <ul style="list-style-type: none"> <li>Auger Housing Height ..... 7, 20</li> <li>Auger Shear Bolt ..... 25</li> <li>Belts ..... 21-23</li> <li>Belt Guide ..... 23</li> <li>Belt Replacements ..... 22, 23</li> <li>Cable ..... 9, 10, 21</li> <li>Carburetor ..... 25, 27</li> <li>Friction Wheel ..... 23, 24</li> <li>Spark Plug ..... 26</li> </ul> </li> <li>Spark Plug ..... 19, 26</li> <li>Specifications ..... 4</li> <li>Speed Governor ..... 26</li> <li>Starting the Engine: <ul style="list-style-type: none"> <li>Electric Start ..... 14</li> <li>Recoil Start ..... 15, 16</li> </ul> </li> <li>Stopping the Engine ..... 12, 14, 15</li> <li>Stopping the Snow Thrower ..... 12</li> <li>Shipping Carton ..... 7</li> <li>Skid Height ..... 7, 20</li> <li>Shifter Lever ..... 10-12</li> <li>Shear Bolts ..... 25</li> <li>Storage ..... 27</li> </ul> <p><b>T</b></p> <ul style="list-style-type: none"> <li>Table of Contents ..... 5</li> <li>Trouble Shooting Chart ..... 28</li> <li>Tools for Assembly ..... 6</li> <li>Traction Drive Belt ..... 21, 23</li> </ul> <p><b>W</b></p> <ul style="list-style-type: none"> <li>Warranty ..... 4</li> </ul>
--	---	--

# CONTENTS OF HARDWARE PACK

## CONTENTS OF PARTS BAG



\*2- Spare Shear Bolts  
(1/4" x 1-3/4 In.)

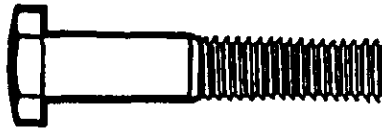

1- 3/8 - 16 x 2.00 In. Hex Head Bolt

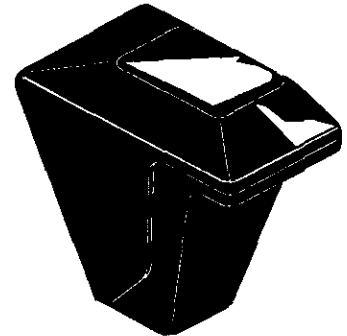

1 - Knob With Threads (not shown actual size)



\*2- Spare Spacers

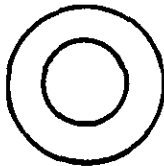

2- 3/8 In. Flat washers



1- 3/8 In. Lock washer



\*2- Spare 1/4 - 20 Locknuts



1- 3/8 In. Hex JamNut



1- 3/8 In. Hex Nut

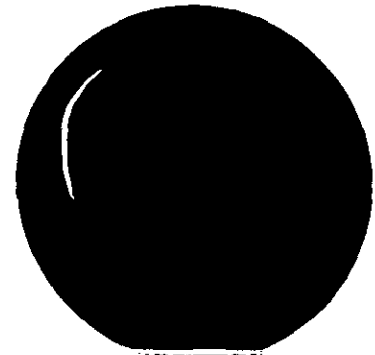

1- Knob With Threads

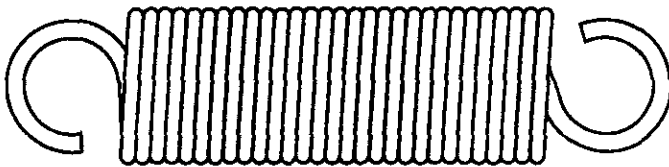

1- Remote Chute Return Spring

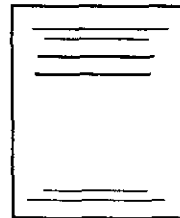

1- Owner's manual

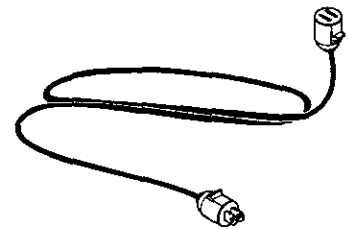

1- Starter Motor Cord 9.5 Ft.



\*Non-Assembly Parts

2- Cable Ties

## Parts packed separately in carton (not shown full size)

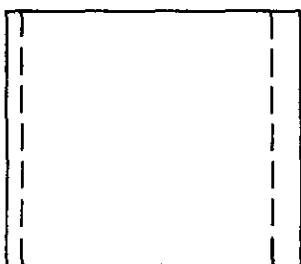

1- Parts Bag



1- container 5W30 oil



2 - Ignition Keys  
(Attached to engine in plastic bag)



1- Crank Assembly

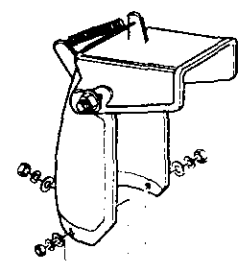

1- Snow Chute Assembly

# ASSEMBLY

## TOOLS REQUIRED FOR ASSEMBLY

- 1 - Knife (to cut carton and plastic ties)
- 2 - 1/2 inch wrenches (or adjustable wrenches)
- 2 - 9/16 inch wrenches (or adjustable wrenches)
- 2 - 3/4 inch wrenches (or adjustable wrenches)
- 1 - Pliers (to spread cotter pin)
- 1 - Screwdriver
- 1 - Measuring tape or ruler

Figure 1 shows the snow thrower in the shipping position.

Figure 2 shows the snow thrower completely assembled.

Reference to the right and left hand side of the snow thrower is from the operator's position at the handle.

## TO REMOVE SNOW THROWER FROM CARTON (See FIG. 1)

- Remove packaging inserts located at four corners of carton.
- Locate and remove container of 5W30 oil found in rear, right, carton insert.
- Cut all four corners of the carton from top to bottom and lay the panels flat.
- Cut and discard plastic ties securing augers and wheel axles to the pallet.
- Cut and discard plastic ties and bags that secure crank assembly and place assembly aside.
- Cut and discard plastic ties securing clutch cables to lower handle.
- Remove plastic wrap from upper handle which was used to protect clutch levers.
- With the two 9/16" wrenches, loosen (but do not remove) both bolts securing the upper and lower handles by holding the inner nut on the inside of the handle while turning the outside bolt counter-clockwise as shown in FIG. 4A, in this section of the manual.
- Swing upper handle up into operating position as shown in FIG. 2. Hold the inner nut and tighten the outside bolt up against the handle.

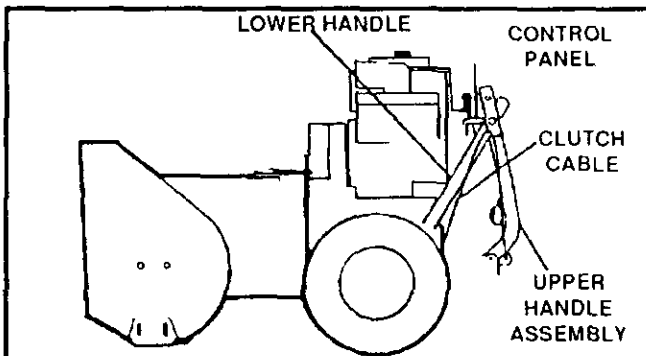

FIG. 1

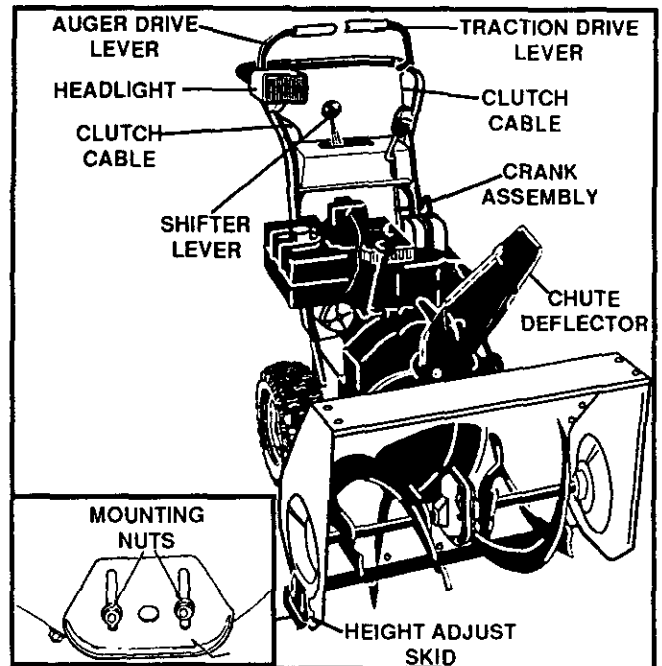
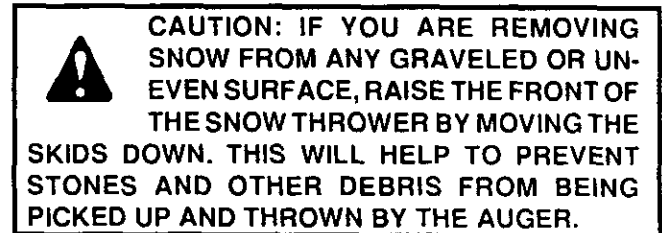

FIG. 2



# ASSEMBLY

- Assemble the snow chute.
- Roll snow thrower off the skid by pulling on the handle.
- Properly dispose of discarded packaging.

## HOW TO SET UP YOUR SNOW THROWER

Your snow thrower is equipped with height adjust skids (See FIG. 2) on the outside of the auger housing. To adjust the skid height, see To Adjust Skid Height paragraph in the Service & Adjustments section of this manual. (See Figure 1 page 20).

## TO ASSEMBLE SNOW CHUTE

- Remove three carriage bolts, flat washers, lock washers and nuts from snow chute flange.
- Position snow chute on snow chute flange and align the three holes in the snow chute with tabs on snow chute flange.
- Replace carriage bolts from inside of chute as shown in FIG. 3, flat washers, lock washers, nuts and tighten.
- Hook remote chute return spring supplied through both spring bracket as on deflector and chute extension.

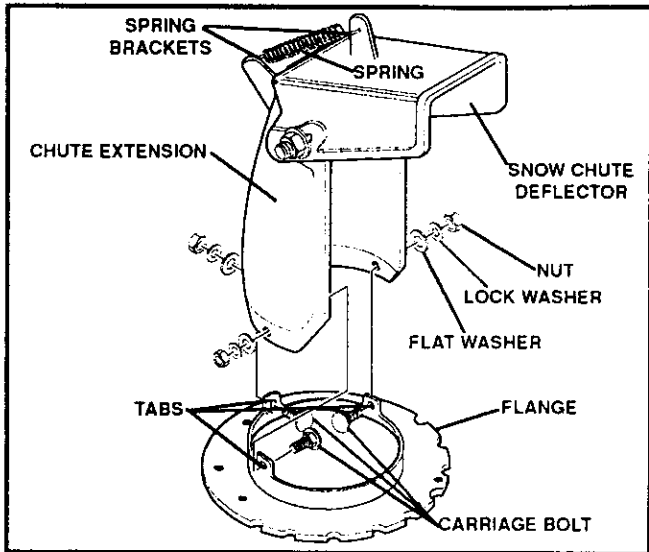

FIG. 3

## TO INSTALL THE UPPER HANDLE AND CRANK ASSEMBLY

- On the right side of the handle, install and secure the following parts (found in parts box) in the lower handle hole as shown in FIG. 4A:

- 1 - 3/8" x 1-3/4" bolt
- 1 - 3/8" flat washers
- 1 - 3/8" lock washer
- 1 - 3/8" nut

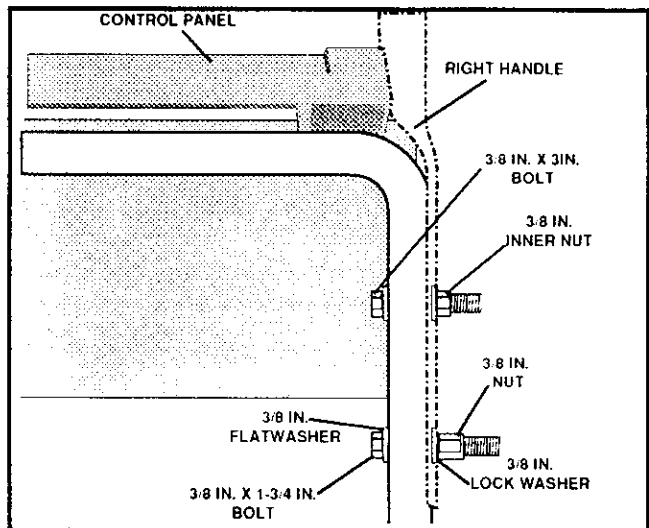

FIG. 4A

- Remove the 3/8" nylon locknut and flat washer from the eye bolt assembly (on the chute crank assembly). Check to make sure the two 3/8" jam nuts are tight. The jam nuts should be 2.75 inches from the end of the eye bolt (FIG. 4B inset).

- Install eye bolt through lower hole on the left hand side of the handle (See FIG. 4B).

- Install the 3/8" flatwasher and the 3/8" nylon locknut loosely on the eye bolt as shown in FIG. 4B.

- Remove the plastic bag from chute crank assembly. Remove the plastic cap, cotter pin and washer from the wormed end of the auger assembly (See FIG. 5 page 9).

- Rotate the notched section of the discharge chute toward the crank-adjusting rod (See FIG. 5 page 9).

- Install the wormed end of the crank through the hole in the adjusting rod and secure the end with the flat washer and cotter pin, as shown in FIG. 5 page 9

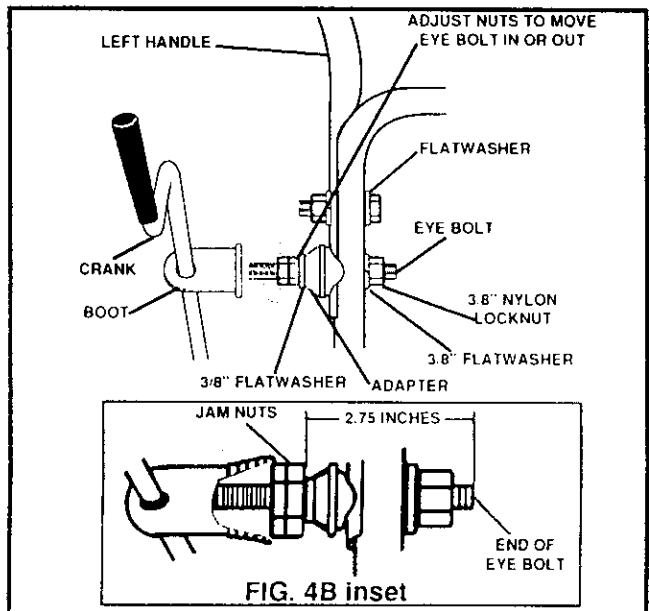

FIG. 4B



# ASSEMBLY

- Bend the ends of the cotter pin around the rod and reinstall the plastic cap.
- Tighten the eye bolt installed earlier, keeping eye in line with the rod while tightening the inside securely.
- Rotate the chute crank fully clockwise and fully counter-clockwise. The discharge chute should rotate fully to the outer diameter of the worm and should clear approximately 1/8" (See FIG. 5). If the chute crank needs to be adjusted, go to the Service and Adjustments section in this manual. Screws securing chute clips at the base of the chute should be slightly loose for easy rotation.

**NOTE:** Be sure the crank does not touch the side of the engine or the cover will be scratched.

## TO INSTALL HEADLIGHT

The headlight is mounted on the right side of the upper handle. It is installed upside down for shipping purposes.

- Remove the pivot bolt nut, lock washer and saddle washer (FIG. 6A) from the headlight mounting bracket. Remove headlight assembly and replace on top side of upper handle with saddle washer, lock washer and pivot bolt nut as shown in FIG. 6B. Tighten nut securely (See Headlight Repair Parts in the Repair Parts section of this manual).
- Tie the headlight cable to upper and lower handles with the plastic cable ties supplied in the parts bag by threading the pointed ends of each tie through the square end and pulling tightly around the headlight cable and the handle.

**NOTE:** One side of the plastic tie has small notches in it, while the other side is smooth. The notched side must be on the inside of the loop which is formed when the ends are put together.

- Try to loosen the cable tie. If it can be loosened, it has been attached with the smooth side on the inside of the loop. Remove the cable tie and reverse its direction.
- Cut off excess plastic tie.

## TO ASSEMBLE CONTROL CABLES

- Install control cables to control levers as shown in FIG. 7 and FIG. 7A.

**NOTE:** If control cables have become unattached from motor mount frame, reconnect cables as shown in FIG 7A.

**NOTE:** Do not tangle headlight cable and clutch control cables.

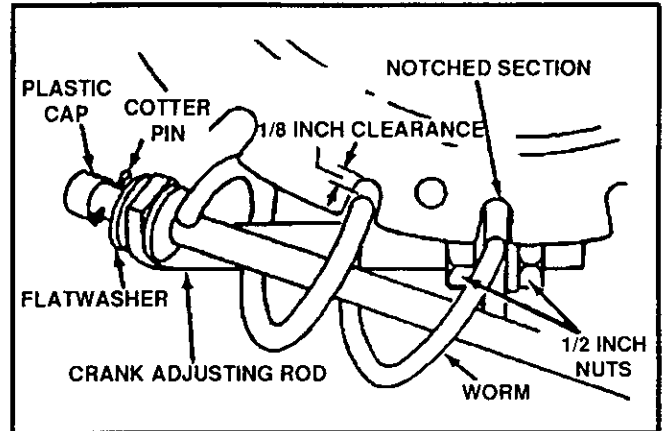

FIG. 5

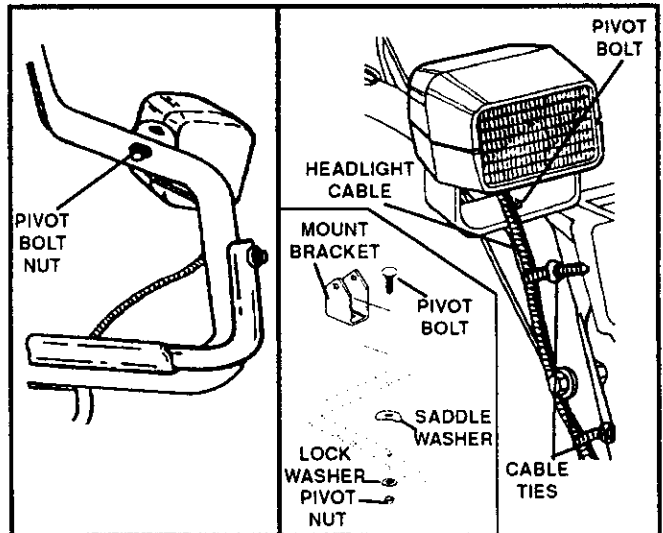

FIG. 6A

FIG. 6B

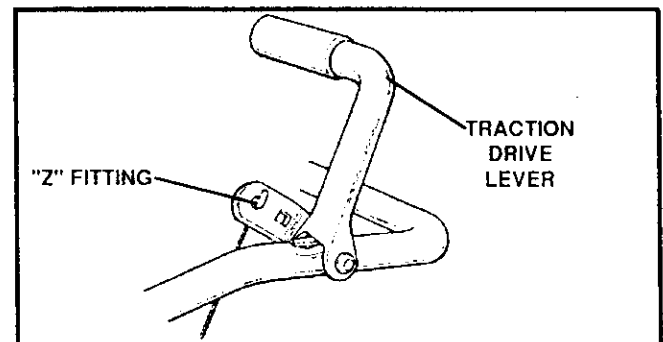

FIG. 7

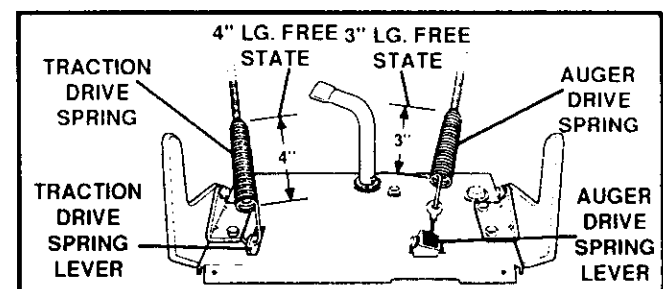

FIG. 7A

# ASSEMBLY

## TO INSTALL THE SHIFTER LEVER

- Stand the snow thrower up on the front of the auger housing, as shown in FIG. 8A. **Note:** Place a piece of cardboard under front to prevent paint damage to auger housing.
- Cut the plastic tie which holds the shifter lever assembly to the shift bracket (FIG. 8B).
- Remove the locknut, washer, spring and bolt (FIG. 8D).
- Reposition the shifter lever into the slot in the control panel, as shown in FIG. 8C, and reinstall the bolt, spring, washer and the locknut.
- Tighten the locknut until  $1/8"$  to  $3/16"$  (2 or 3 threads) of the bolt protrude past the locknut.
- Thread the shifter lever knob onto the threaded end of the shifter lever until it is tight (FIG. 8D).
- Move the shifter lever through all the speeds to ensure proper tension of the spring. If the shifter lever sticks in any of the notches, loosen the locknut  $1/4$  turn at a time until the shifter lever moves freely.
- Return the snow thrower to the normal operating position.

## TO CHECK/ADJUST CLUTCH CONTROL CABLES

The control cables attached to the auger clutch lever and traction clutch lever may need to be adjusted before you use your snow thrower.

For instructions on checking or adjusting the control cables, see To Adjust Clutch Control Cables paragraph in the Service & Adjustments section of this manual.

### ✓ CHECKLIST

*BEFORE YOU OPERATE AND ENJOY YOUR NEW SNOW THROWER, WE WISH TO ASSURE THAT YOU RECEIVE THE BEST PERFORMANCE AND SATISFACTION FROM THIS QUALITY PRODUCT.*

*PLEASE REVIEW THE FOLLOWING CHECKLIST:*

- ✓ All assembly instructions have been completed.
- ✓ The discharge chute rotates freely.
- ✓ No remaining loose parts in carton.

*WHILE LEARNING HOW TO USE YOUR SNOW THROWER, PAY EXTRA ATTENTION TO THE FOLLOWING IMPORTANT ITEMS:*

- ✓ Engine oil is at proper level.
- ✓ Make sure gas tank is filled properly with clean, fresh, unleaded gasoline.
- ✓ Become familiar with all controls-their location and function. Operate controls before starting engine.

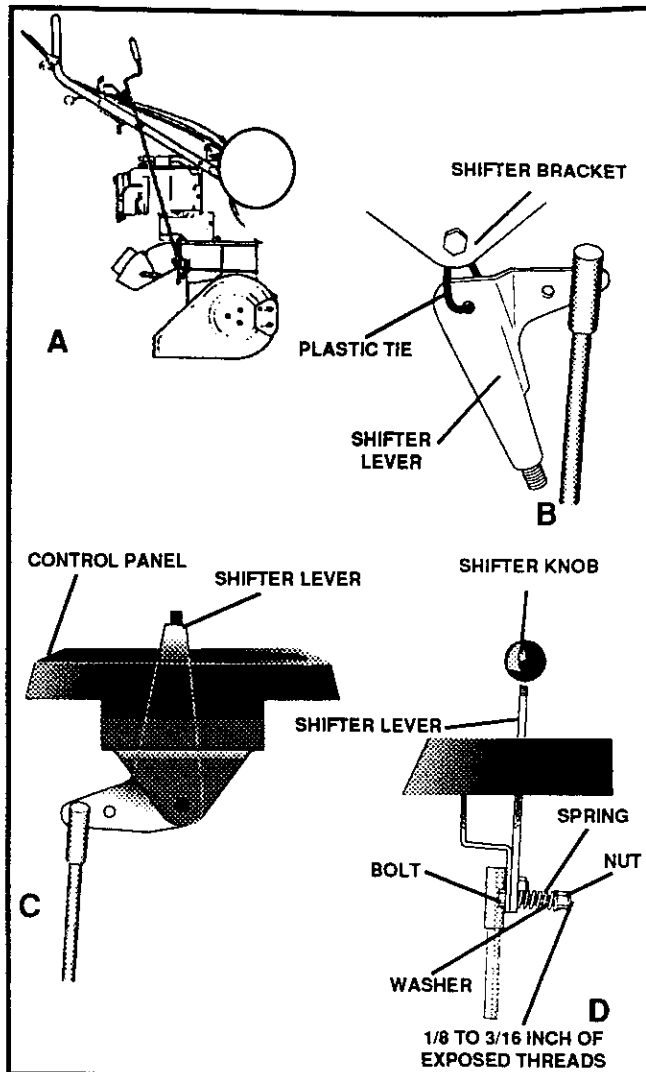
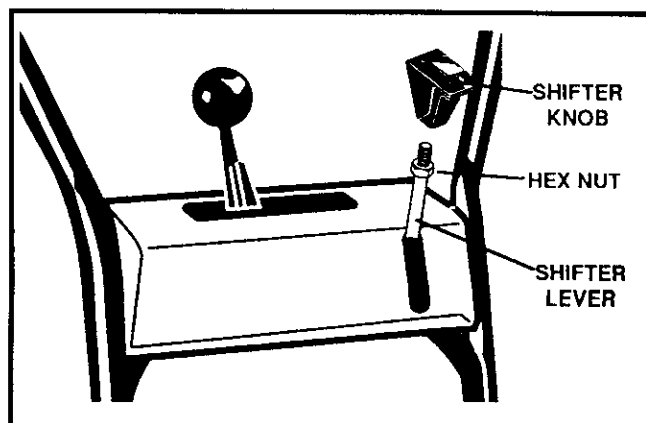

FIG.8

## TO INSTALL SHIFTER LEVER KNOB

- Thread the shifter lever knob onto the threaded end of the shifter lever until it is snug against the hex nut and the lip is pointed toward the engine. Tighten the hex nut against the bottom of the shift lever knob (See Fig. 9).



# OPERATION

## KNOW YOUR SNOW THROWER

READ THIS OWNER'S MANUAL AND SAFETY RULES BEFORE OPERATING YOUR SNOW THROWER. Compare the illustrations with your snow thrower to familiarize yourself with the location of various controls and adjustments. Save this manual for future reference.

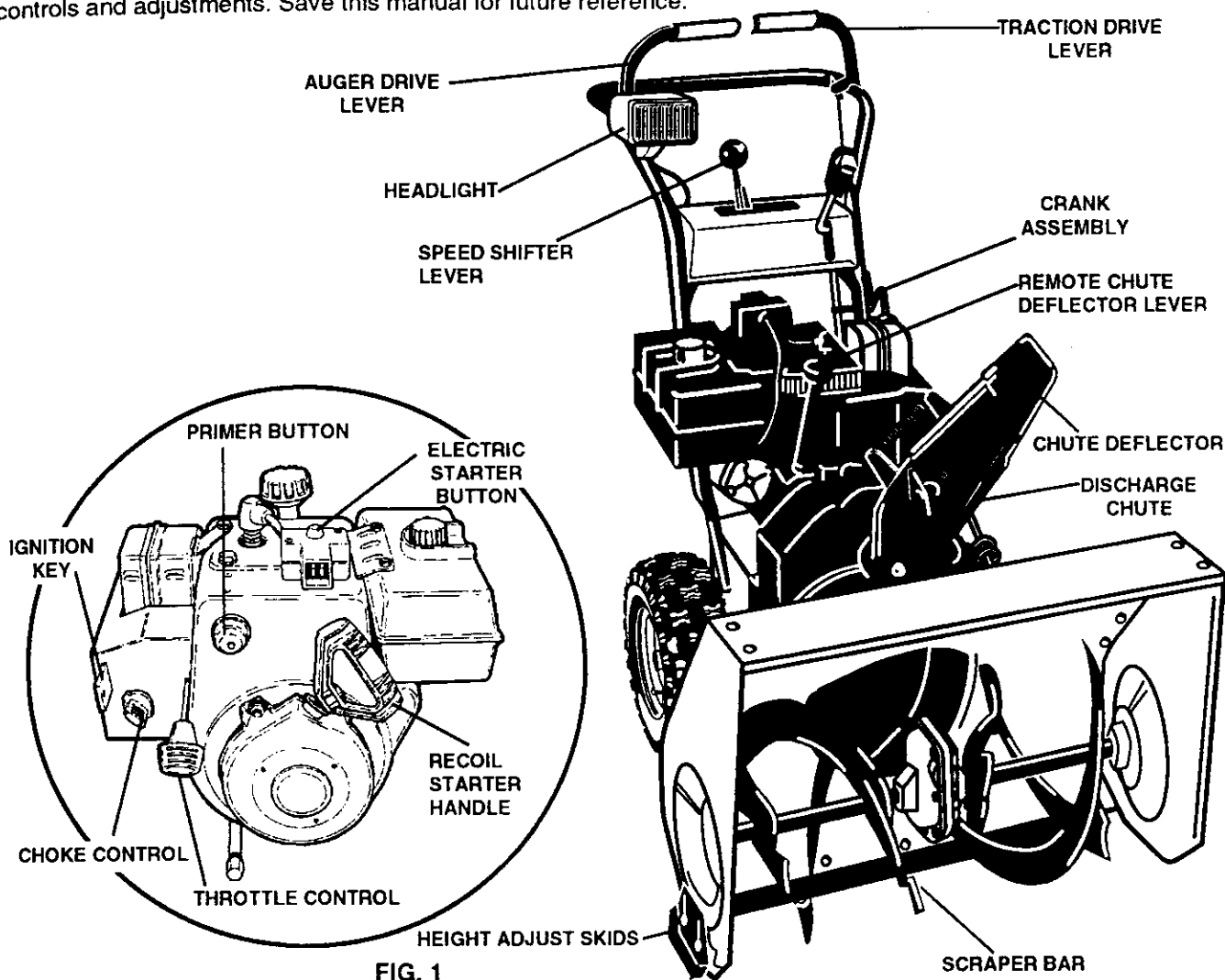

FIG. 1

SEARS SNOW THROWERS conform to the safety standards of the American National Standards Institute, B71.3-1984.

**AUGER DRIVE LEVER** - Starts and stops the auger and impeller (snow gathering and throwing).

**TRACTION DRIVE LEVER** - Propels the snow thrower forward and in reverse.

**SPEED SHIFTER LEVER** - Selects the speed of the snow thrower (6 speeds forward and 2 speeds reverse).

**HEADLIGHT** - Turns on whenever the engine is running.

**CRANK ASSEMBLY** - Changes the direction of snow throwing through the discharge chute.

**CHUTE DEFLECTOR** - Changes the height and distance the snow is thrown.

**DISCHARGE CHUTE** - Changes the direction the snow is thrown.

**IGNITION KEY** - Must be inserted to start the engine.

**ELECTRIC STARTER BUTTON** - Used to start the engine using the 120 V electric starter.

**RECOIL STARTER HANDLE** - Starts the engine manually.

**CHOKE CONTROL** - Used to start a cold engine.

**PRIMER BUTTON** - Injects fuel directly into the carburetor manifold for fast starts in cold weather.

**THROTTLE CONTROL** - Controls the engine speed.

**HEIGHT ADJUST SKIDS** - Adjusts the ground clearance of the auger housing.

**REMOTE CHUTE DEFLECTOR LEVER** - Push forward to discharge snow high and far. Pull remote lever back to discharge snow down

# OPERATION



The operation of any snow thrower can result in foreign objects being thrown into the eyes, which can result in severe eye damage. Always wear safety glasses or eye shields while operating the snow thrower.

We recommend standard safety glasses or wide vision safety mask for over your glasses available at SEARS Retail Stores or Service Centers.

## HOW TO USE YOUR SNOW THROWER

### TO STOP YOUR SNOW THROWER

- To stop throwing snow, release the auger drive lever (See FIG. 4).
- To stop the traction drive, release the traction drive lever. (See FIG. 4)
- To stop the engine, push the throttle control lever to off and pull out the ignition key (See FIG. 3).

**NOTE:** Do not turn key.

### TO CONTROL SNOW DISCHARGE

- Turn the crank assembly to set the **direction** of the snow throwing.
- Adjust snow chute deflector to set the **distance**. Push remote lever forward to discharge snow high and far. Pull remote lever back to discharge snow down. (FIG. 2).

### TO MOVE FORWARD AND BACKWARD

- To shift, release the traction drive lever and move the speed shifter lever to the speed you desire. Ground speed is determined by snow conditions. Select the speed you desire by moving the speed shifter lever into the appropriate area on the control panel.

Speeds 1, 2 - Wet, Heavy, Extra Deep

Speed 3 - Moderate

Speeds 4, 5 - Very Light

Speed 6 - Transport only

- Engage the traction drive lever (See FIG. 4, left hand). As the snow thrower starts to move, maintain a firm hold on the handles, and guide the snow thrower along the clearing path. Do not attempt to push the snow thrower.
- To move the snow thrower backward, move the speed shifter lever into first or second reverse and engage the traction drive lever (left hand).

**IMPORTANT:** NEVER MOVE THE SPEED SHIFTER LEVER WHILE THE TRACTION LEVER IS DOWN.

### TO THROW SNOW

- Push down the auger drive lever (See FIG. 4, right hand).
- Release to stop throwing snow.

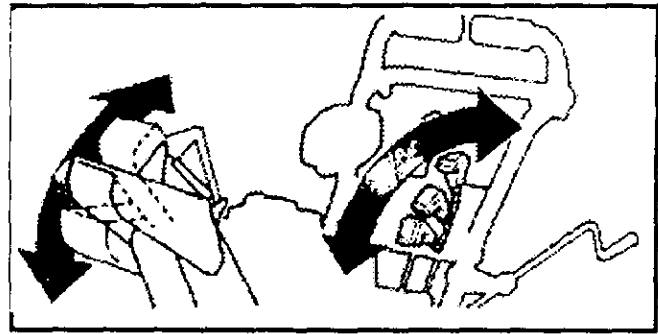

FIG. 2

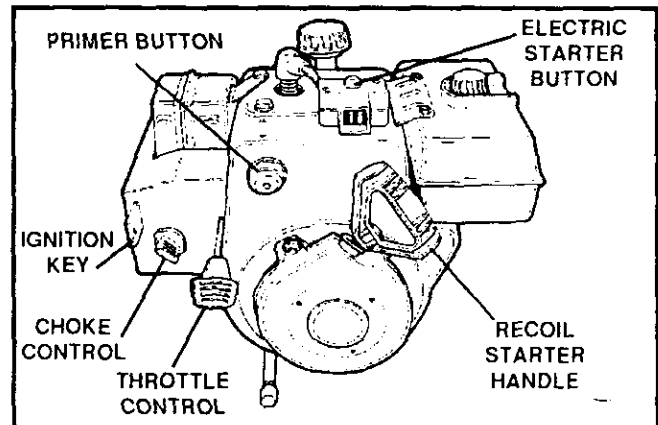

FIG. 3

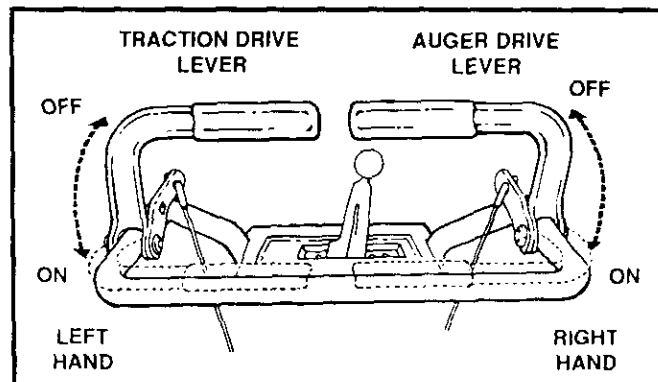

FIG. 4



**CAUTION: READ OWNER'S MANUAL BEFORE OPERATING MACHINE. NEVER DIRECT DISCHARGE TOWARD BYSTANDERS. STOP THE ENGINE BEFORE UNCLOGGING DISCHARGE CHUTE OR AUGER HOUSING AND BEFORE LEAVING THE MACHINE.**

# OPERATION

## TO USE WHEEL LOCKOUT PIN

- The left hand wheel is secured to the axle with a klick pin (See FIG. 5A). This unit was shipped with this klick pin in the locked (through wheel hole) position.
- For ease of maneuverability in light snow conditions, disconnect the klick pin from the wheel locked position and push into the single wheel drive (unlocked axle hole only) position (See FIG. 5B).
- Make sure that the klick pin is in the single wheel drive position of the axle only and not through the locked position.

## BEFORE STARTING THE ENGINE

### FILL OIL:

This snowthrower was shipped with a container of 5W30 oil. This oil must be added to the engine before operating. Remove the oil fill cap/dipstick and fill the crank case to FULL line on dipstick (26 ounces) (See FIG. 6) with S.A.E. 5W-30 motor oil.

**NOTE:** Engine may already contain some residual oil. Check frequently when filling the crankcase. Do not over fill.

Tighten the fill cap/dipstick securely each time you check the oil level.

**NOTE:** Oil must be changed after the first 2 hours of operation to extend engine life.

**NOTE:** For extreme cold operating conditions of 0°F. and below, use a partial synthetic 0W30 motor oil for easier starting.

### FILL GAS:

Fill the fuel tank with clean, fresh, unleaded grade automotive gasoline. Be sure that the container you pour the gasoline from is clean and free from rust or other foreign particles. Never use gasoline that may be stale from long periods of storage in the container.

**NOTE:** S.A.E. 5W-30 motor oil may be used to make starting easier in areas where temperature is consistently 20° F. or lower.

**WARNING:** Experience indicates that alcohol blended fuels (called gasohol or those using ethanol or methanol) can attract moisture which leads to separation and formation of acids during storage. Acidic gas can damage the fuel system of an engine while in storage.

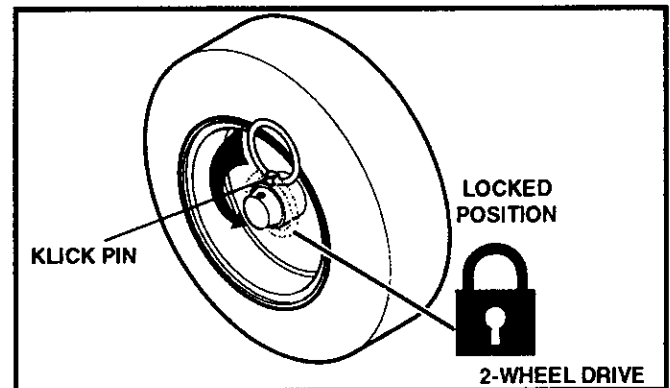

FIG. 5A

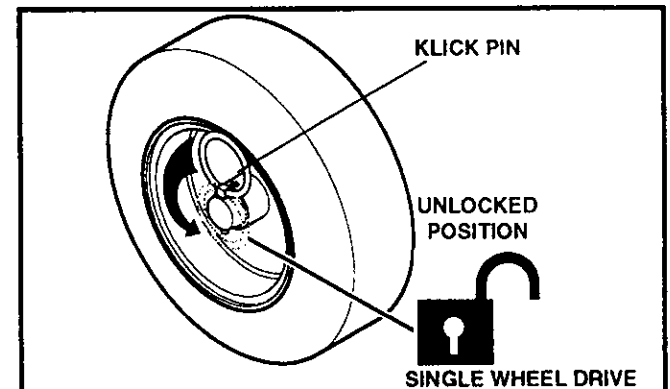

FIG. 5B

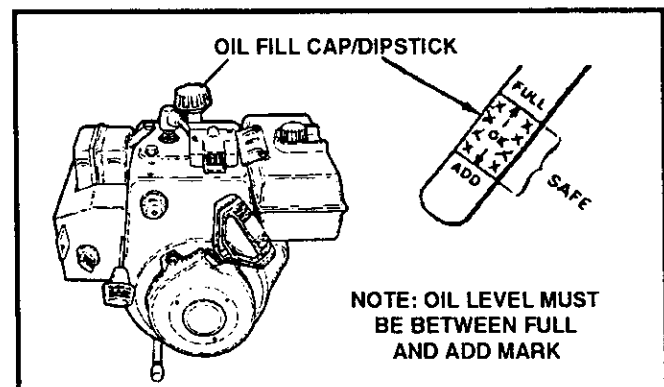

FIG.6

To avoid engine problems, the fuel system should be emptied before storage for 30 days or longer. Start the engine and let it run until the fuel lines and carburetor are empty. Use the carburetor bowl drain to empty residual gasoline from the float chamber (FIG. 1 in the Storage section of this manual). Use fresh fuel next season. (See Storage section in this manual for additional information.)

Never use engine or carburetor cleaner products in the fuel tank or permanent damage may occur.

# OPERATION



**CAUTION: GASOLINE IS FLAMMABLE AND CAUTION MUST BE USED WHEN HANDLING OR STORING IT.**

**DO NOT FILL FUEL TANK WHILE SNOW THROWER IS RUNNING, WHEN IT IS HOT, OR WHEN SNOW THROWER IS IN AN ENCLOSED AREA.**

**KEEP AWAY FROM OPEN FLAME OR AN ELECTRICAL SPARK AND DO NOT SMOKE WHILE FILLING THE FUEL TANK.**

**NEVER FILL THE TANK COMPLETELY. FILL THE TANK TO WITHIN 1/4" - 1/2" FROM THE TOP TO PROVIDE SPACE FOR EXPANSION OF FUEL.**

**ALWAYS FILL FUEL TANK OUTDOORS AND USE A FUNNEL OR SPOUT TO PREVENT SPILLING.**

**MAKE SURE TO WIPE UP ANY SPILLED FUEL BEFORE STARTING THE ENGINE.**

**STORE GASOLINE IN A CLEAN, APPROVED CONTAINER AND KEEP THE CAP IN PLACE ON THE CONTAINER.**

## TO STOP ENGINE

- To stop engine, move the throttle control lever to STOP position and remove key. Keep the key in a safe place. The engine will not start without the key.

## TO START ENGINE (Electric Starter)

Be sure that the engine has sufficient oil. The snow thrower engine is equipped with a 120 volt A.C. electric starter and recoil starter. Before starting the engine, be certain that you have read the following information:

### COLD START (See FIG. 7)

- Be sure the auger drive and traction drive levers are in the disengaged **RELEASED** position.
- Move the throttle control to **RUN** position.
- Remove the keys from the plastic bag. Insert one key into the ignition slot. Be sure it snaps into place. **DO NOT TURN KEY**. Keep the second key in a safe place.
- Rotate the choke knob to **FULL** choke position.
- Connect the power cord to the switch box on the engine.
- Plug the other end of the power cord into a three-hole, grounded 120 volt A.C. receptacle.
- Push the primer button while covering the vent hole as follows: (**Remove finger from primer button between primes**).

Do not prime if temperature is above 50°F.

Two times if temperature is 50°F to 15°F.

Four times if temperature is below 15°F.

- Push down on the starter button until the engine starts. Do not crank for more than 10 seconds at a time. This electric starter is thermally protected. If overheated it will stop automatically and can be restarted only when it has cooled to a safe temperature (a wait of about 5 to 10 minutes is required).
- When the engine starts, release the starter button and slowly rotate the choke to **OFF** position. If the engine falters, rotate the choke to **FULL** and then gradually to **OFF**.
- Disconnect the power cord from the receptacle first and then from switch box on engine.

**NOTE:** Allow the engine to warm up for a few minutes because the engine will not develop full power until it reaches operating temperature.

- Run the engine at full throttle **RUN** when throwing snow.

## WARM START

If restarting a warm engine after a short shutdown, leave choke at **OFF** and do not push the primer button.

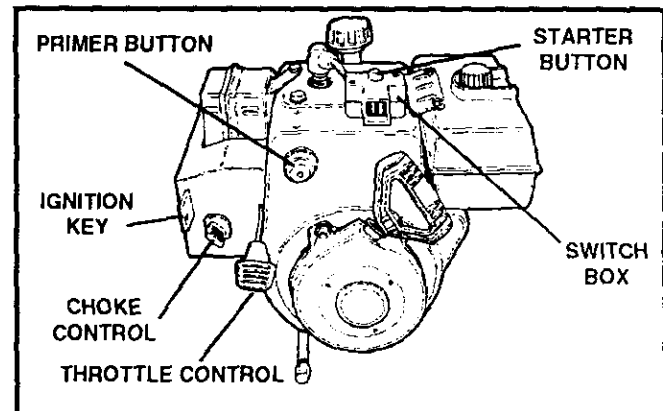

FIG.7

# OPERATION



**CAUTION: THIS STARTER IS EQUIPPED WITH A THREE-WIRE POWER CORD AND PLUG AND IS DESIGNED TO OPERATE ON 120 VOLT AC HOUSEHOLD CURRENT. IT MUST BE PROPERLY GROUNDED AT ALL TIMES TO AVOID THE POSSIBILITY OF ELECTRICAL SHOCK, WHICH MAY BE INJURIOUS TO OPERATOR. FOLLOW ALL INSTRUCTIONS CAREFULLY AS SET FORTH IN THE "TO START ENGINE" SECTION. DETERMINE THAT YOUR HOUSE WIRING IS A THREE-WIRE GROUNDED SYSTEM. ASK A LICENSED ELECTRICIAN IF YOU ARE NOT SURE. IF YOUR HOUSE WIRE SYSTEM IS NOT A THREE-WIRE SYSTEM, DO NOT USE THIS ELECTRIC STARTER UNDER ANY CONDITIONS. IF YOUR SYSTEM IS GROUNDED AND A THREE-HOLE RECEPTACLE IS NOT AVAILABLE AT THE POINT YOUR STARTER WILL NORMALLY BE USED, ONE SHOULD BE INSTALLED BY A LICENSED ELECTRICIAN.**

**WHEN CONNECTING 120 VOLT AC POWER CORD, ALWAYS CONNECT THE CORD TO THE SWITCH BOX ON THE ENGINE FIRST, THEN PLUG THE OTHER END INTO THE THREE-HOLE GROUNDED RECEPTACLE.**

**WHEN DISCONNECTING POWER CORD, ALWAYS UNPLUG THE END IN THE THREE-HOLE GROUNDED RECEPTACLE FIRST.**

## TO STOP ENGINE

- To stop engine, move the throttle control lever to **STOP** position and remove key. Keep the key in a safe place. The engine will not start without the key.

## TO START ENGINE (Recoil Starter)

Be sure that the engine has sufficient oil. Before starting the engine, be certain that you have read the following information:

### COLD START (See FIG. 8)

- Be sure the auger drive and the traction drive levers are in the disengaged **RELEASED** position.
- Move the throttle control up to **RUN** position.
- Push the key into the ignition slot. Be sure it snaps into place. Do not turn key. Remove the plastic bag and extra key.
- Rotate choke control to **FULL** choke position.
- Press the primer button in cold weather. Press two or three times, while keeping your finger over the vent hole on the primer button. Release finger between primes. Additional priming may be necessary for the first start if the temperature is below 15° F. Do not prime if temperature is above 50° F.

**CAUTION: NEVER RUN ENGINE INDOORS OR IN ENCLOSED, POORLY VENTILATED AREAS. ENGINE EXHAUST CONTAINS CARBON MONOXIDE, AN ODORLESS AND DEADLY GAS. KEEP HANDS, FEET, HAIR AND LOOSE CLOTHING AWAY FROM ANY MOVING PARTS ON ENGINE AND SNOW THROWER.**

**WARNING: TEMPERATURE OF MUFFLER AND NEARBY AREAS MAY EXCEED 150° F. AVOID THESE AREAS.**

**DO NOT ALLOW CHILDREN OR YOUNG TEENAGERS TO OPERATE OR BE NEAR SNOW THROWER WHILE IT IS OPERATING.**

- Pull the starter handle rapidly. Do not allow the handle to snap back, but allow it to rewind slowly while keeping a firm hold on the starter handle.
- As the engine warms up and begins to operate evenly, rotate the choke knob slowly to **OFF** position. If the engine falters, return to **FULL** choke, then slowly move to **OFF** choke position.

**NOTE:** Allow the engine to warm up for a few minutes because the engine will not develop full power until it reaches operating temperature.

- Run the engine at or near the top speed when throwing snow.

## WARM START

If restarting a warm engine after a short shutdown, rotate choke to **OFF** instead of **FULL** and do not push the primer button.

## FROZEN RECOIL STARTER

If the starter is frozen and will not turn engine:

- Pull as much rope out of the starter as possible.
- Release the starter handle and let it snap back against the starter.

If the engine still fails to start, repeat. If continued attempts do not free starter, follow the electric starter procedures to start.

To help prevent possible freeze-up of recoil starter and engine controls, proceed as follows after each snow removal job.

- **With the engine running**, pull the starter rope hard with a continuous full arm stroke three or four times. Pulling of starter rope will produce a loud clattering sound. This is not harmful to the engine or starter.
- **With the engine not running**, wipe all snow and moisture from the carburetor cover in area of control levers. Also move throttle control, choke control, and starter handle several times.

# OPERATION

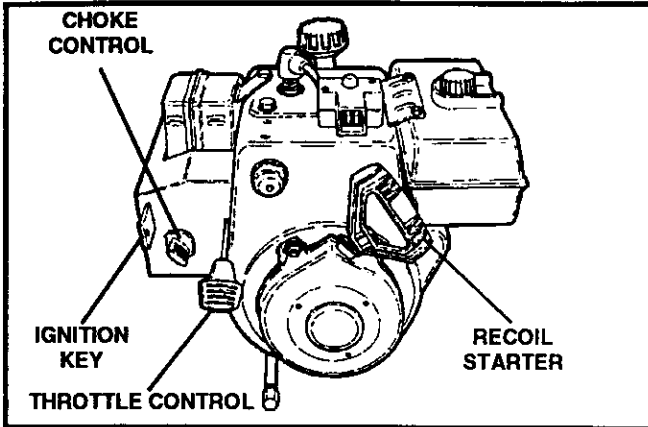

FIG. 8

## SNOW THROWING TIPS

- For maximum snow thrower efficiency in removing snow, adjust ground speed, never the throttle. Go slower in deep, freezing, or wet snow. If the wheels, reduce forward speed. The engine is designed to deliver maximum performance at full throttle and should be run at this power setting at all times.
- Most efficient snow blowing is accomplished when the snow is removed immediately after it falls.
- For complete snow removal, slightly overlap each path previously taken.
- The snow should be discharged down wind whenever possible.
- For normal usage, set the skids so that the scraper bar is 1/8" above the skids. For extremely hard-packed snow surfaces, adjust the skids upward so that the scraper bar touches the ground.
- On gravel or crushed rock surfaces, set the skids at 1-1/4" below the scraper bar (see **To Adjust Skid Height** paragraph in the **Service & Adjustments** section of this manual). Stones and gravel must not be picked up and thrown by the machine.
- If the front of the snow thrower has a tendency to raise, reduce the ground speed and engage the weight transfer system.
- After the snow blowing job has been completed, allow the engine to idle for a few minutes, which will melt snow and accumulated ice off the engine.
- Clean the snow thrower thoroughly after each use.
- Remove ice and snow accumulation and all debris from the entire snow thrower, and flush with water (if possible) to remove all salt or other chemicals. Wipe snow thrower dry.



**CAUTION: DO NOT ATTEMPT TO REMOVE ANY ITEM THAT MAY BECOME LODGED IN AUGER WITHOUT TAKING THE FOLLOWING PRECAUTIONS:**

- **RELEASE AUGER DRIVE AND TRACTION DRIVE LEVERS.**
- **MOVE THROTTLE LEVER TO STOP POSITION.**
- **REMOVE (DO NOT TURN) IGNITION KEY.**
- **DISCONNECT SPARK PLUG WIRE.**
- **DO NOT PLACE YOUR HANDS IN THE AUGER OR DISCHARGE CHUTE. USE A PRY BAR.**



# CUSTOMER RESPONSIBILITIES

SERVICE RECORDS Fill in dates as you complete regular service	SCHEDULE							SERVICE DATES					
	After First 2 hours	Before Each Use	As Needed	Every 10 Hours	Every 25 Hours	Each Season	Before Storage						
Check Engine Oil Level		✓				✓							
Change Engine Oil	✓				✓	✓							
Tighten All Screws and Nuts	✓	✓	✓										
Check Traction Clutch Cable Adjustment (See Cable Adjustment)	✓					✓							
Replace Spark Plug					✓	✓							
Adjust Drive Belts	✓				✓	✓							
Lubricate All Pivot Points				✓			✓						
Lubricate Auger Shaft (See Shear Bolt Replacement)							✓						
Lubricate Disc Drive Plate Zerk					✓		✓						
Drain Fuel							✓						
Check Auger Clutch Cable Adjustment (See Cable Adjustment)	✓					✓							

## GENERAL RECOMMENDATIONS

The warranty on this snow thrower does not cover items that have been subjected to operator abuse or negligence. To receive full value from the warranty, operator must maintain snow thrower as instructed in this manual.

Some adjustments will need to be made periodically to properly maintain your snow thrower .

All adjustments in the Service and Adjustments section of this manual should be checked at least once each season.

### AFTER FIRST USE

- Check for any loose or damaged parts.
- Tighten any loose fasteners.
- Check and maintain the auger.
- After each use, remove all snow and slush off the snow thrower to prevent freezing of auger or controls.
- Check controls to make sure they are functioning properly.
- If any parts are worn or damaged, replace immediately.

## LUBRICATION CHART

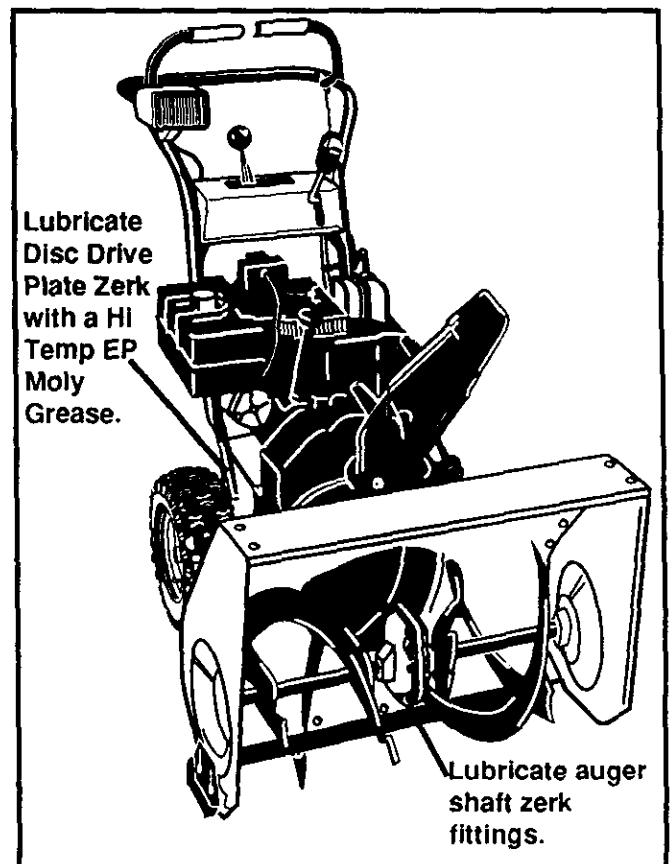

# CUSTOMER RESPONSIBILITIES

## SNOW THROWER

### LUBRICATION - EVERY TEN HOURS

- Auger Shaft - Using a hand grease gun, lubricate the auger shaft zerk fittings (See A, FIG. 2) every ten (10) operating hours. Each time a shear bolt is replaced (See To Replace Auger Shear Bolt paragraph in the Service & Adjustments section of this manual), the auger shaft **MUST** be greased.
- For storage or when replacing shear bolts, remove shear bolts and lubricate auger shaft zerks. Rotate augers several times on the shaft and reinstall the shear bolts.

### LUBRICATION - EVERY 25 HOURS

- Position speed selector lever in first gear.
- Place a coin or (a shim of equal thickness) between the rubber friction wheel and disc drive plate to prevent friction wheel contacting the friction disc.
- Disc Drive Plate - Using a hand grease gun, lubricate with a Hi Temp EP Moly grease, zerk located beneath the disc drive plate (See FIG. 3 inset) every 25 hours and at the end of the season and/or before storage. To grease zerk, turn disc drive plate clockwise by hand until zerk is clearly visible at front center. **DO NOT** overfill or allow grease to come in contact with the disc drive plate or friction wheel or damage will result. Fill zerk only until grease becomes visible below bearing assembly located under grease zerk. See Lubrication Chart in this section.
- **IMPORTANT:** Remove coin and ensure that a gap exists between friction wheel and disc drive plate.
- **NOTE:** Clean all excess grease found on friction disc hub.
- **CAUTION:** Do not allow grease to contact friction wheel and disc drive plate.

### LUBRICATION - BEFORE STORAGE

- Remove both wheels, grease (any automotive type grease) both axles (See FIG. 1) and replace wheels. Do this at least once a year and/or prior to storage.

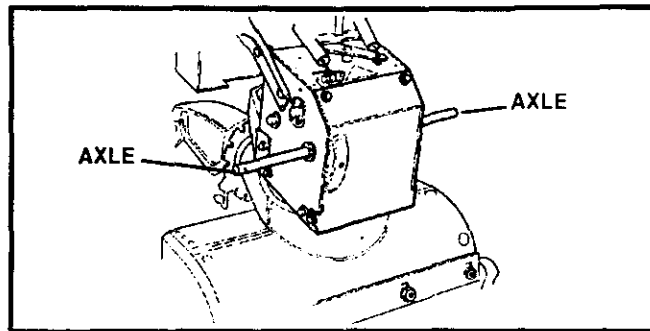

FIG. 1

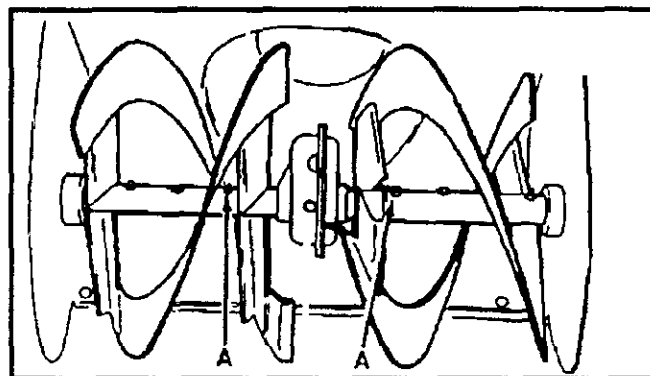

FIG. 2

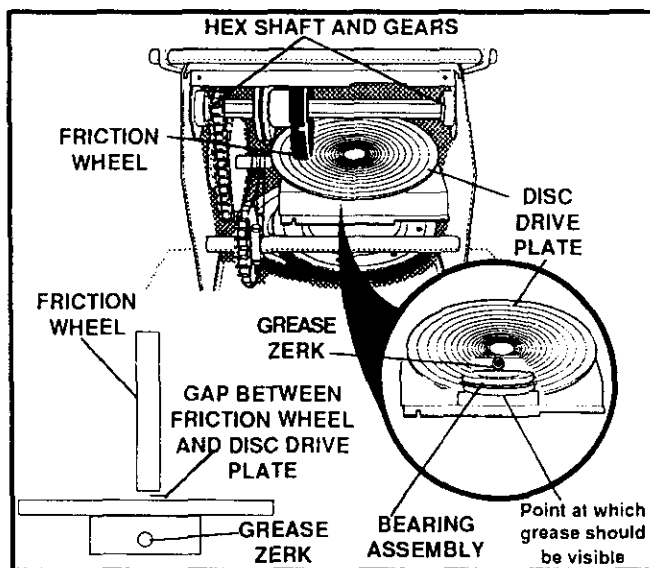

FIG. 3

# CUSTOMER RESPONSIBILITIES

## LUBRICATION

- Hex Shaft and Gears - Hex shaft and gears require no lubrication. All bearings and bushings are lifetime lubricated and require no maintenance (See FIG. 3).

**NOTE:** Any greasing or oiling of the above components can cause contamination of the friction wheel. If the disc drive plate or friction wheel come in contact with grease or oil, damage to the friction wheel will result.

Should grease or oil come in contact with the disc drive plate or friction wheel, be sure to clean the plate and wheel thoroughly.

**NOTE:** For storage, the hex shaft and gears should be wiped with 5W-30 motor oil to prevent rusting (See FIG. 3).

- Auger Gear Box - The auger gear box has been factory lubricated for life. If for some reason lubricant should leak out, have the auger gear case checked by a competent repairman.

## ENGINE

### LUBRICATION

Check the crankcase oil level (See FIG. 4) before starting the engine and after each five (5) hours of continuous use. Add S.A.E. 5W-30 motor oil as needed. Tighten fill cap/dipstick securely each time you check the oil level.

### OIL RECOMMENDATION

Only use high quality detergent oil rated with API service classification SG. Select the oil's viscosity grade according to your expected operating temperature:

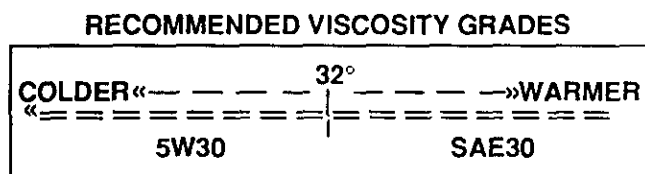

**NOTE:** For extreme cold operating conditions of 0° F. and below, use a partial synthetic 5W30 motor oil for easier starting.

**NOTE:** Although multi-viscosity oils improve starting in cold weather, these multi-viscosity oils will result in increased oil consumption when used above 32°F. Check your engine oil level more frequently to avoid possible engine damage from running low on oil.

- Position snow thrower so that the oil drain plug is lowest point on the engine. Remove oil drain plug and oil fill cap/dipstick. Drain oil into a suitable container. Oil will drain more freely when warm.
- Replace oil drain plug and tighten securely. Refill crankcase with S.A.E. 5W-30 motor oil.

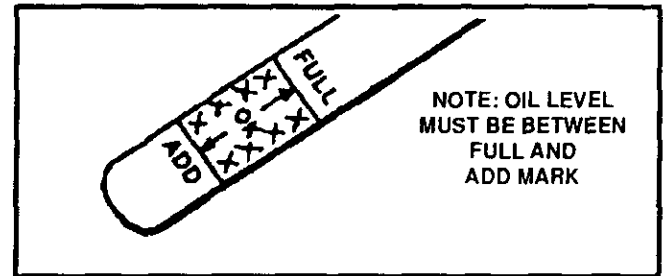

FIG. 4

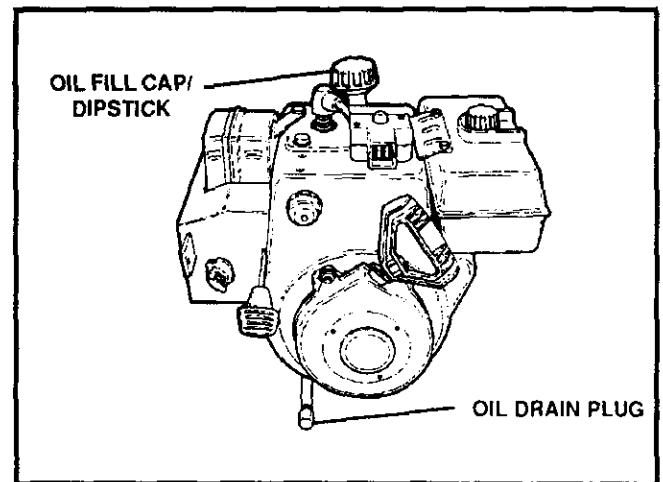

FIG. 5

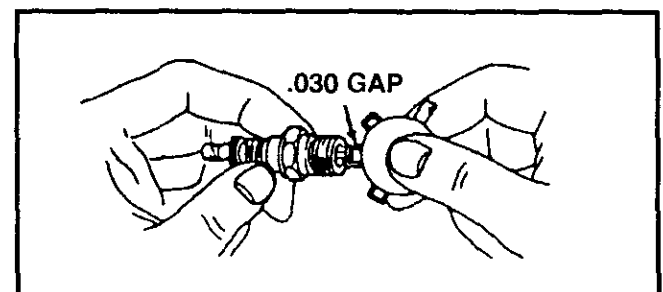

FIG. 6

### SPARK PLUG

- Make sure that the spark plug is tightened securely into the engine and the spark plug wire is attached to the spark plug.
- If a torque wrench is available, torque plug to 18 to 23 foot pounds.
- Clean the area around the spark plug base before removal to prevent dirt from entering the engine.
- Clean the spark plug and reset the gap periodically to .030 inch (See FIG. 6).

# SERVICE AND ADJUSTMENTS



**CAUTION: ALWAYS DISCONNECT THE SPARK PLUG WIRE AND TIE BACK AWAY FROM THE PLUG BEFORE MAKING ANY ADJUSTMENTS OR REPAIRS.**

## TO ADJUST SKID HEIGHT

This snow thrower is equipped with two height adjustment skids, located on the outside of the auger housing (See FIG. 1). These skids elevate the front of the snow thrower. For normal hard surfaces such as a paved driveway or walk, adjust the skids as follows:

- Check tire pressure (14 to 17 pounds). See side of tire for maximum inflation. Do not exceed maximum pressure on side of tire.
- Place the extra shear bolts supplied (found in parts bag) under each end of the scraper bar near but not under the skid.
- Loosen the skid mounting nuts (See FIG. 1) and adjust the skids up to bring the front of the snow thrower down. Re-tighten the mounting nuts.
- Set the skid on the other side at the same height.

For rocky or uneven surfaces, adjust the skids as follows:

- Raise the front of the snow thrower by moving the skids down. This will help prevent rocks and other debris from being picked up and thrown by the auger.

**NOTE:** Be sure that snow thrower is set at same height on both sides.

## TO ADJUST SCRAPER BAR

After considerable use, the metal scraper bar will have a definite wear pattern. The scraper bar in conjunction with the skids should always be adjusted to allow 1/8" between the scraper bar and the sidewalk or area to be cleaned.

- Position the snow thrower on a level surface.
- Loosen the carriage bolts and nuts securing the scraper bar to the auger housing.
- Adjust the scraper bar to the proper position.
- Tighten the carriage bolts and nuts, making sure that the scraper bar is parallel with the working surface.



**CAUTION: BE CERTAIN TO MAINTAIN PROPER GROUND CLEARANCE FOR YOUR PARTICULAR AREA TO BE CLEARED. OBJECTS SUCH AS GRAVEL, ROCKS OR OTHER DEBRIS, IF STRUCK BY THE IMPELLER, MAY BE THROWN WITH SUFFICIENT FORCE TO CAUSE PERSONAL INJURY, PROPERTY DAMAGE OR DAMAGE TO THE SNOW THROWER.**

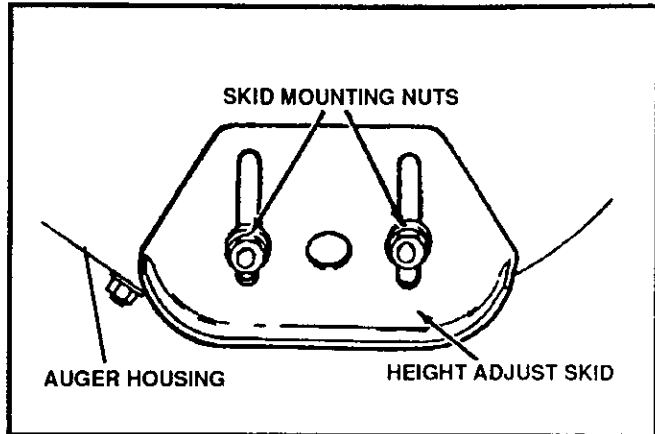

FIG. 1

- After extended operation, the scraper bar may be reversed. If the scraper bar must be replaced due to wear, remove the carriage bolts and nuts and install a new scraper bar.

## TO ADJUST CHUTE CRANK ASSEMBLY

If you cannot rotate the chute crank fully to the left and to the right, you need to adjust the chute crank (See FIG. 2).

- Loosen both 1/2" nuts on the crank adjusting rod (using 3/4" wrenches).
- Rotate the adjusting rod in or out to allow about 1/8" clearance between the notch in the flange and the outer diameter of the worm.
- Once this clearance is set, tighten the nuts.

**NOTE:** Be sure the crank does not touch the side of the engine or the cover will be scratched.

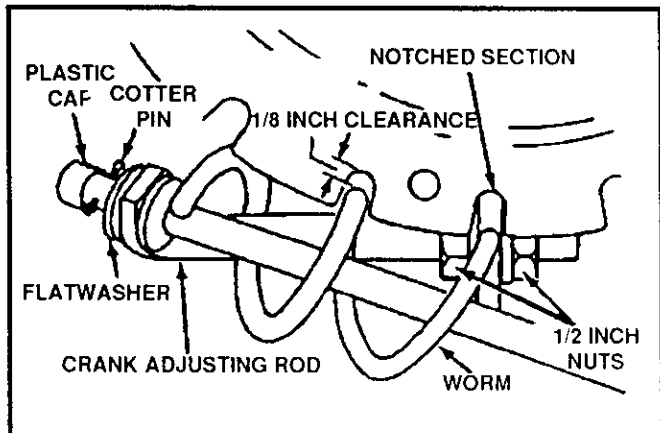

FIG. 2

# SERVICE AND ADJUSTMENTS

## TO ADJUST THE CLUTCH CONTROL CABLES

Periodic adjustment of the cables may be required due to normal stretch and wear on the belts. To check for correct adjustment, the control lever must be in the full forward position, resting on the plastic bumper. The control cables are correctly adjusted when the center of the "Z" Fitting is between the center and top of the hole in the clutch lever and there is no droop in the cable (See FIG. 3).

If adjustment is necessary:

- Remove gas from gas tank. Stand blower on end.
- Disconnect the "Z" Fitting from drive lever.
- Pull spring cover up to expose spring. Push the cable through the spring (See FIG. 4) to expose the threaded portion of the cable.
- Hold the square end of the threaded portion with pliers and adjust the locknut in until the excess slack is removed (See FIG. 4 inset).
- Pull the cable back through the spring and connect the cable. Do the same for the other lever cable.

**NOTE:** Whenever the traction drive or auger belts are adjusted or replaced, the cables will need to be adjusted.

## TO ADJUST BELTS

Belts stretch during normal use. If you need to adjust the belts due to wear or stretch, proceed as follows:

### TRACTION DRIVE BELT (See FIG. 6)

The traction drive belt has constant spring pressure and does not require adjustment. Check the clutch control cable adjustment before replacing the belt.

Replace the traction drive belt if it is still slipping (See To Replace Belts paragraph in this section).

### AUGER DRIVE BELT (See FIG. 6)

If your snow thrower will not discharge snow, check the control cable adjustment. If it is correct, then check the condition of the auger drive belt. It may be loose or damaged. If it is damaged, replace it. See To Replace Belts paragraph in this section. If the auger drive belt is loose, adjust as follows:

- Disconnect the spark plug wire.
- Remove the belt cover (See FIG. 7 in this section).
- Loosen the nut on the idler pulley (See FIG. 5) and move the pulley toward the belt about 1/8".
- Tighten the nut.
- Press the auger drive lever. Check the tension on the belt (**opposite idler pulley**). The belt should deflect about 1/2" with moderate pressure (See FIG. 5).

**NOTE:** You may have to move the idler pulley more than once to obtain the correct tension.

- Replace the belt cover.

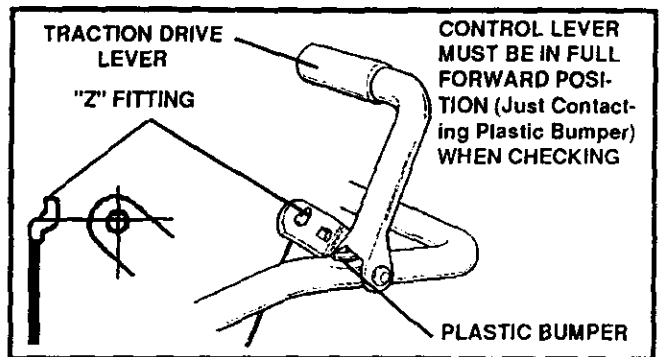

FIG. 3

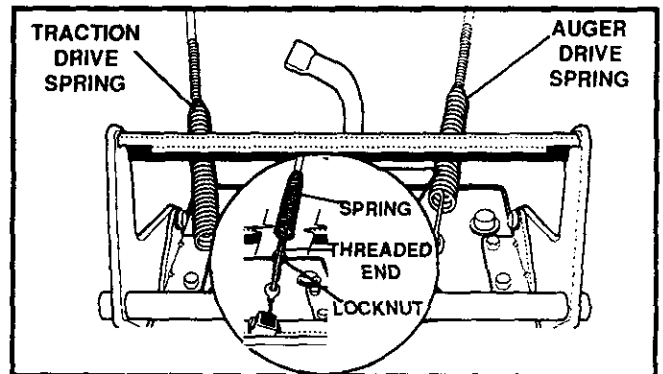

FIG. 4

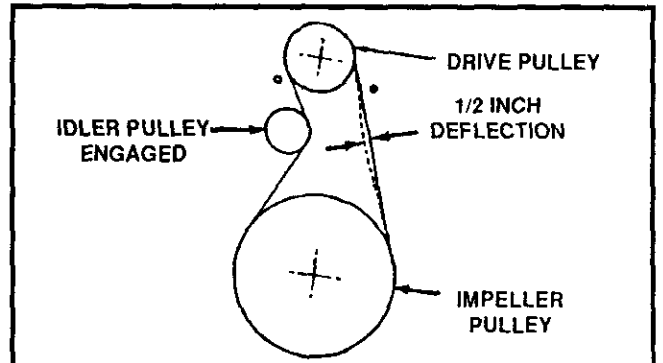

FIG. 5

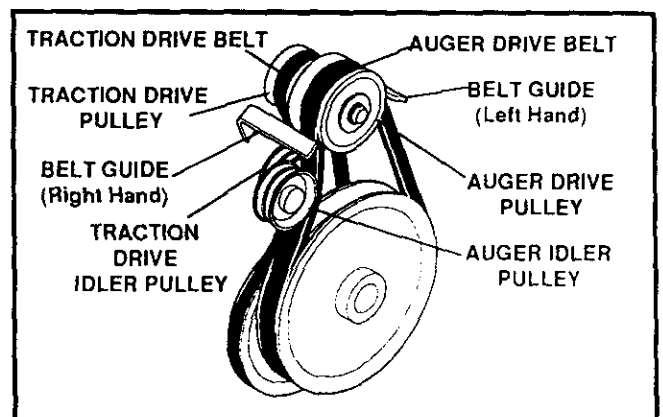

FIG. 6

- Check the clutch control cable adjustment.
- Reconnect the spark plug wire.

# SERVICE AND ADJUSTMENTS

## TO REPLACE BELTS

The drive belts on this snow thrower are of special construction and should be replaced with original equipment belts available from your nearest Sears Store or Service Center.

You will need the assistance of a second person while replacing the belts.

Drain the gasoline from the fuel tank by removing the fuel line. Drain the gas and reinstall fuel line.



**CAUTION: DRAIN THE GASOLINE OUT DOORS, AWAY FROM FIRE OR FLAME.**

## AUGER DRIVE BELT

If your snow thrower will not discharge snow, and the auger drive belt is damaged, replace it as follows:

- Disconnect the spark plug wire.
- Remove the belt cover (See FIG. 7).
- Loosen the belt guides (See FIG. 8) and pull away from the engine drive pulley.
- Loosen nut on auger idler pulley (See FIG. 9) and pull idler pulley away from belt.
- Remove top two bolts that secure auger housing to motor mount frame. Loosen bottom two bolts. Auger housing and motor mount frame will separate hinged by bottom two bolts.
- Remove brake arm from housing. Do not remove spring.
- Remove old belt from the auger drive engine pulley.
- Install the same type replacement belt on auger pulley.
- Reinstall brake arm into housing. Ensure brake arm is fully inserted into housing and brake pad is riding in pulley groove.
- Position belt onto the engine drive pulley.
- Replace top two bolts; re-tighten bottom two bolts.
- Adjust the drive belt (See To Adjust Auger Drive Belt paragraph in this section).
- Adjust the belt guides (See To Adjust The Belt Guides paragraph in this section).
- Reinstall the belt cover.
- Check clutch control cable adjustment (See To Adjust Clutch Control Cables in this section).
- Reconnect the spark plug wire.

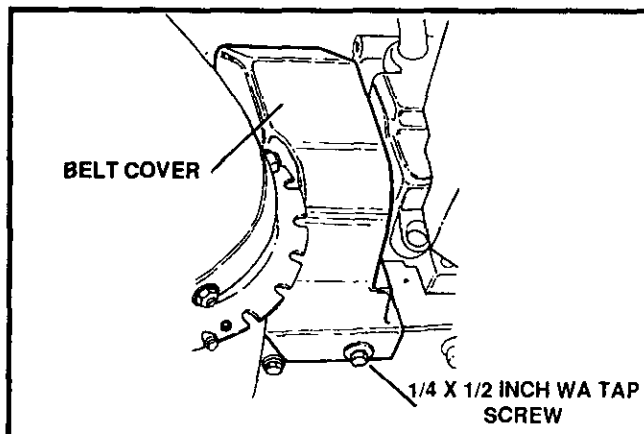

FIG. 7

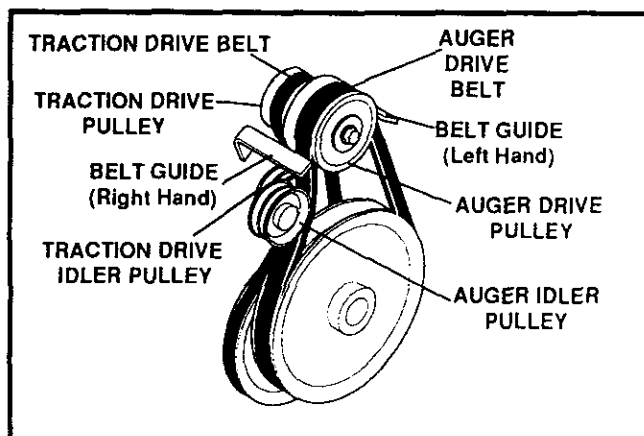

FIG. 8

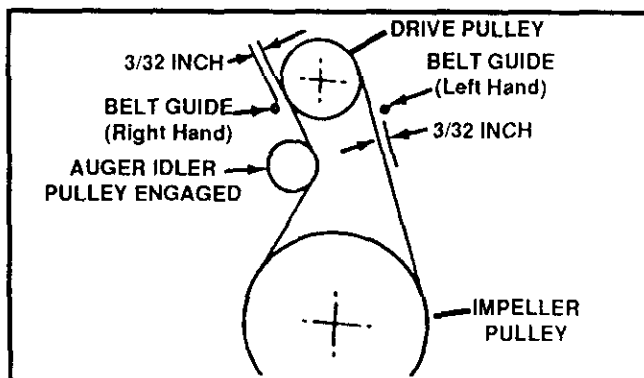

FIG. 9

# SERVICE AND ADJUSTMENTS

## TRACTION DRIVE BELT

If your snow thrower will not move forward, check the traction drive belt for wear. If the traction drive belt needs to be replaced, proceed as follows:

- Disconnect the spark plug wire.
- Remove the belt cover (See FIG. 7 in this section).
- Loosen belt guides (See FIG. 8) and pull belt guides away from the engine drive pulley.
- Loosen nut on auger idler and pull auger idler pulley away from belt.
- Remove auger drive belt from engine pulley.
- Pull drive belt idler pulley away from drive belt. Remove drive belt.
- Position new drive belt onto traction pulley.
- Pull idler pulley away from belt, allowing belt to be positioned onto engine pulley.
- Release idler pulley. Ensure idler pulley is properly engaged with belt.
- Reinstall auger drive belt.
- Adjust belt guides (See To Adjust The Belt Guides paragraph below).
- Adjust idler on auger belt.
- Reinstall the belt cover.
- Reconnect the spark plug wire.

## TO ADJUST THE BELT GUIDES

After you replace a track or auger drive belt, you need to adjust one or both of the belt guides. Proceed as follows:

- Disconnect the spark plug wire.
- Remove the belt cover (See FIG. 7 in this section).
- Engage the auger drive clutch lever.
- Measure the distance between the belt guides and the belt (See FIG. 9 in this section). The distance should be 3/32" for each guide.
- If adjustment is necessary, loosen the belt guide mounting bolts. Move the belt guides to the correct position. Tighten the mounting bolts.
- Reinstall the belt cover.
- Reconnect the spark plug wire.

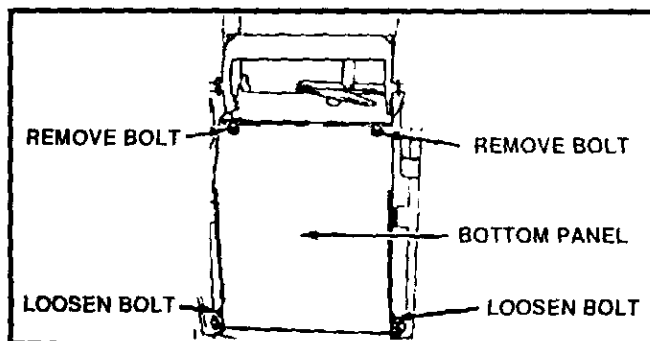

FIG. 10

## TO ADJUST THE FRICTION WHEEL

If the snow thrower will not move forward, you need to check the traction drive belt, the traction drive cable or the friction wheel. If the friction wheel is damaged, it will need to be replaced. See the To Replace Friction Wheel paragraph in this section. If the friction wheel is not worn, check the adjustment, as follows:

- Disconnect the spark plug wire.
- Drain the gasoline from the gas tank.
- Stand snow thrower on the auger housing end.
- Remove the bottom panel (See FIG. 10).
- Position the shifter lever in first (1) forward gear.
- Note the position of the friction wheel on the disc drive plate. The right outer side of the disc drive plate should be 3" from the center of the friction wheel (See FIG. 11).

If adjustment is necessary:

- Loosen nut "A" on the speed select rod. Remove the ball joint by removing nut "B" from the shift yoke assembly. Lengthen or shorten the rod by turning the adaptor to obtain the correct friction wheel position (See FIG. 12).
- Reinstall the ball joint and nut "B." Tighten nut "A."
- Reinstall the bottom panel.

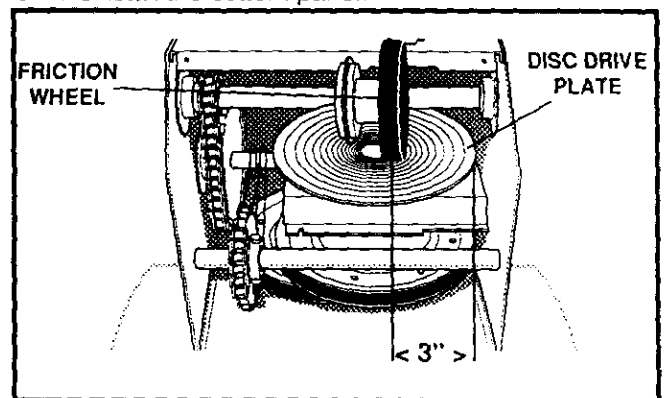

FIG. 11

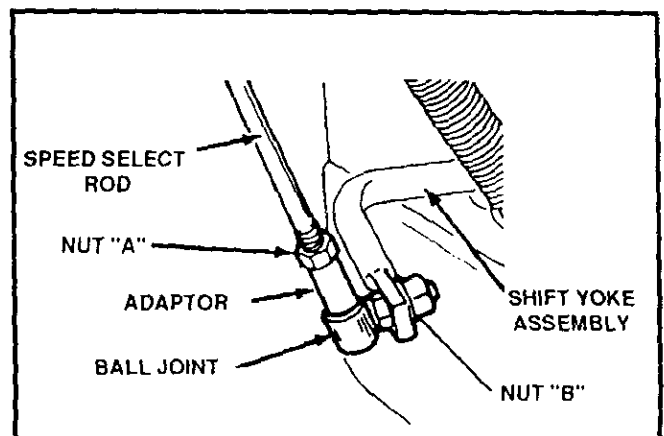

FIG. 12

# SERVICE AND ADJUSTMENTS

## TO REPLACE FRICTION WHEEL

If the snow thrower will not move forward, and the friction wheel is worn or damaged, you need to replace it, as follows: (First allow the engine to cool).



**CAUTION: DRAIN GASOLINE OUTDOORS AWAY FROM FIRE OR FLAME.**

- Drain the gasoline from the fuel tank.
- Disconnect the spark plug wire.
- Stand the snow thrower up on the auger housing end (See FIG. 15).
- Remove the bottom panel (See FIG. 13).
- Remove ball joint from shift yoke assembly (See FIG. 12 in this section).
- Remove the three (3) fasteners securing the friction wheel to the hub (See FIG. 14), and set fasteners aside.
- Remove the four bolts securing bearing plates (both sides) (See FIG. 15).

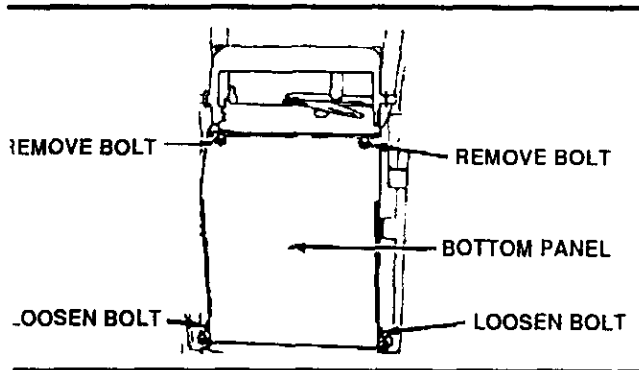

FIG. 13

- Remove the right side bearing plate. Leave hex shaft in original position.
- Remove friction wheel from hub. Slip friction wheel off hex shaft towards right side.

Position new friction wheel onto hub. See FIG. 15.

Install bearing plates to original position. Ensure hex shaft is engaged with both bearing plates.

Secure bearing plates using bolts removed earlier.

Secure friction wheel to hub using fasteners removed earlier. Ensure hex shaft turns freely.

Reinstall ball joint to shift yoke assembly.

Should friction wheel require adjustment, see To Adjust The Friction Wheel in this section.

**NOTE:** Ensure friction wheel and friction disc are free from grease or oil.

Replace bottom panel.

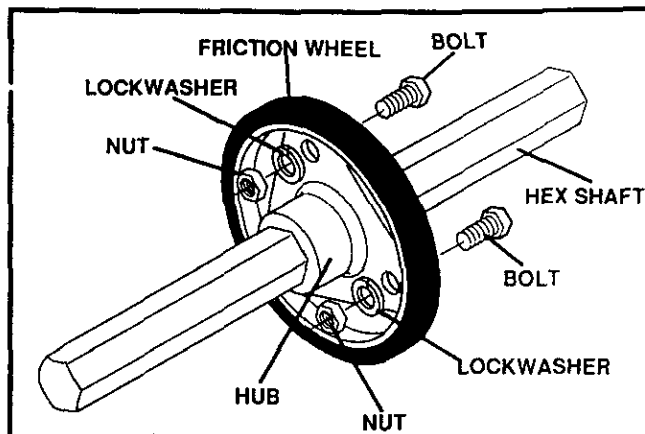

FIG. 14

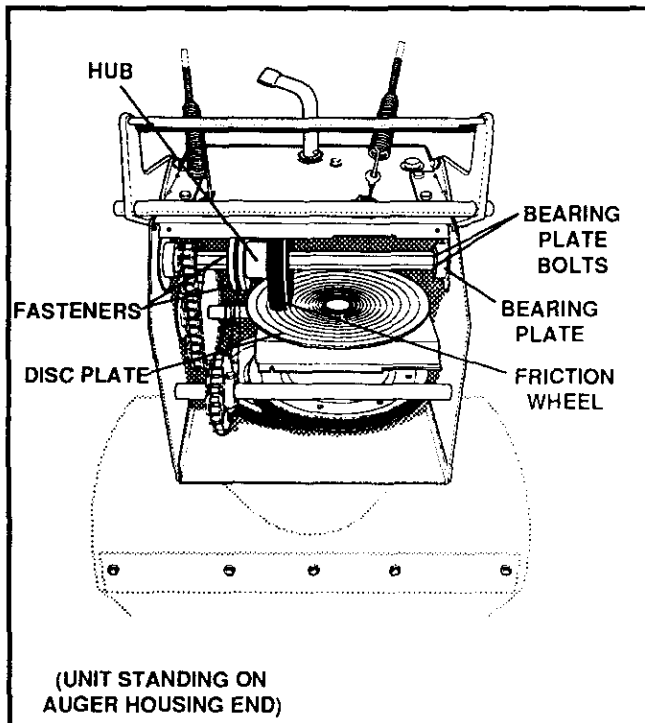

FIG. 15



# SERVICE AND ADJUSTMENTS

## TO REPLACE AUGER SHEAR BOLT

The augers are secured to the auger shaft with special bolts (See FIG. 16) that are designed to break (to protect the machine) if an object becomes lodged in the auger housing. Use of a harder bolt will destroy the protection provided by the shear bolt.

**IMPORTANT:** TO INSURE SAFETY AND PERFORMANCE LEVELS, ONLY ORIGINAL EQUIPMENT SHEAR BOLTS SHOULD BE USED. WHEN REPLACING SHEAR BOLTS, BE SURE TO REPLACE SHEAR BOLT SPACERS.

To replace a broken shear bolt, proceed as follows:

- Move the throttle to **STOP** and turn off all controls.
- Disconnect the spark plug wire. Be sure all moving parts have stopped.
- Remove the broken shear bolt.
- Lubricate the auger shaft zerk fitting (See the **Customer Responsibilities** section in this manual).
- Align the hole in the auger with the hole in the auger shaft. Install the new shear bolt and shear bolt spacer provided.
- Reconnect the spark plug wire.

## TO ADJUST CARBURETOR

The carburetor (See FIG. 17 and (FIG. 1 Storage) has been pre-set at the factory and readjustment should not be necessary. However, if the carburetor does need to be adjusted, proceed as follows:

- Close the high speed adjusting screw by hand.
- Do not over-tighten.
- Then open it 1-1/4 to 1-1/2 turns.
- Close the idle adjusting screw by turning clockwise by hand. Do not over-tighten.
- Then open it 1-1/4 to 1-1/2 turns.
- Start the engine and let it warm up.
- Set the throttle control to **RUN**. Adjust the high speed adjusting screw **in** until the engine speed or sound alters. Adjust the screw **out** until the engine speed sound alters. Note the difference between the two limits and set the screw in the middle of the range.
- Set the throttle control to **SLOW**. Adjust the idle adjusting screw **in** until the engine speed drops, then adjust the screw **out** until the engine speed drops. Note the difference between the two limits and set the screw in the middle of the range.
- If the engine tends to stall under load or not accelerate from low speed to high speed properly, adjust the high speed screw out in 1/8 turn increments until the problem is resolved.

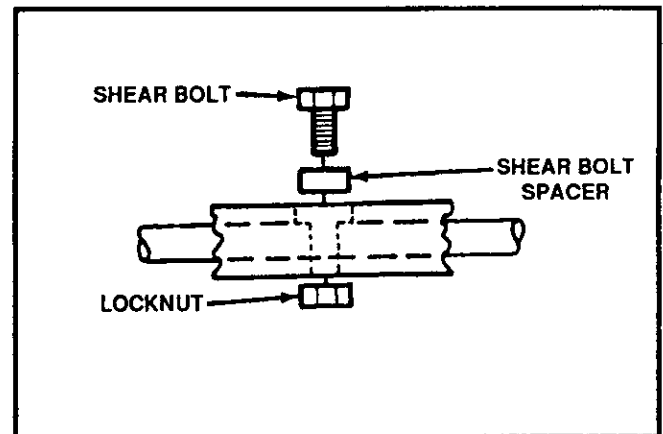

FIG. 16

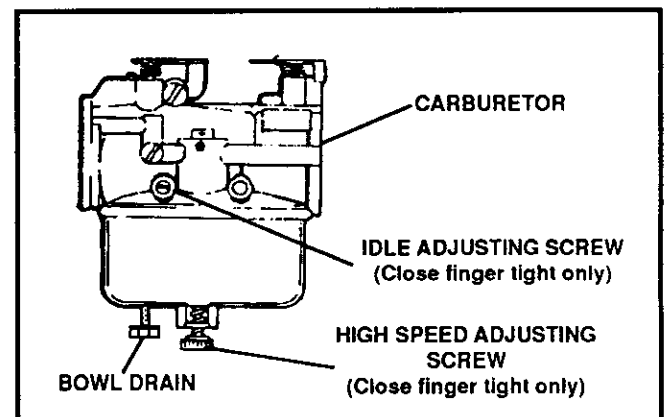

FIG. 17

- Let the engine run undisturbed for 30 seconds between each setting to allow the engine to react to the previous adjustments.

**IMPORTANT:** NEVER TAMPER WITH THE ENGINE GOVERNOR, WHICH IS FACTORY SET FOR PROPER ENGINE SPEED. OVERSPEEDING THE ENGINE ABOVE THE FACTORY HIGH SPEED SETTING CAN BE DANGEROUS. IF YOU THINK THE ENGINE GOVERNED HIGH SPEED NEEDS ADJUSTING, CONTACT YOUR NEAREST SEARS SERVICE CENTER, WHICH HAS THE PROPER EQUIPMENT AND EXPERIENCE TO MAKE ANY NECESSARY ADJUSTMENTS.

# SERVICE AND ADJUSTMENTS

## TO ADJUST OR REPLACE THE SPARK PLUG

If you have difficulty starting your snow thrower, you may need to adjust or replace the spark plug. Follow the instructions below.

Replace the spark plug if electrodes are pitted or burned or if the porcelain is cracked.

### TO ADJUST:

- Clean the spark plug by carefully scraping electrodes (do not sand blast or use a wire brush).
- Be sure the spark plug is clean and free of foreign material. Check electrodes gap (See FIG. 18) with a wire feeler gauge and reset the gap to .030 inch if necessary.

### TO REPLACE:

- If you need a new spark plug, use only the proper replacement spark plug (See page 4).
- Set the gap to .030.
- Before installing the spark plug, coat its threads lightly with oil or grease to insure easy removal.
- Tighten the plug firmly into the engine.
- If a torque wrench is available, torque the plug to 18 to 23 ft - lbs.

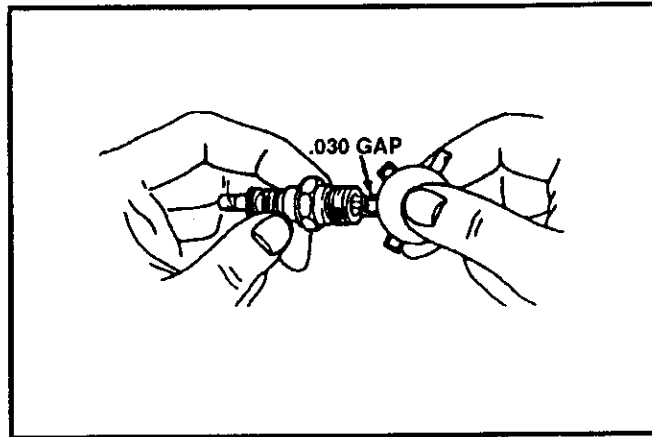

FIG. 18

# STORAGE



**CAUTION: NEVER STORE YOUR SNOW THROWER INDOORS OR IN AN ENCLOSED, POORLY VENTILATED AREA IF GASOLINE REMAINS IN THE TANK. FUMES MAY REACH AN OPEN FLAME, SPARK OR PILOT LIGHT FROM A FURNACE, WATER HEATER, CLOTHES DRYER, CIGARETTE, ETC.**

To prevent engine damage (if snow thrower is not used for more than 30 days) follow the steps below.

## SNOW THROWER STORAGE

- Thoroughly clean the snow thrower.
- Lubricate all lubrication points (See the Customer Responsibilities section in this manual).
- Be sure that all nuts, bolts and screws are securely fastened. Inspect all visible moving parts for damage, breakage and wear. Replace if necessary.
- Touch up all rusted or chipped paint surfaces; sand lightly before painting.
- Cover the bare metal parts of the blower housing auger and the impeller with rust preventative, such as a spray lubricant.

**NOTE:** A yearly checkup or tune-up by a SEARS Service Center is a good way to insure that your snow thrower will provide maximum performance for the next season.

## ENGINE STORAGE

Gasoline must be removed or treated to prevent gum deposits from forming in the tank, filter, hose, and carburetor during storage. Also during storage, alcohol blended gasoline that uses ethanol or methanol (sometimes called gasohol) attracts water. It acts on the gasoline to form acids which damage the engine.

- To remove gasoline, run the engine until the tank is empty and the engine stops. Then drain remaining gasoline from carburetor by pressing upward on bowl drain located on the bottom of carburetor (See FIG. 1).
- If you do not want to remove gasoline, a fuel stabilizer (Such as Craftsman Fuel Stabilizer No. 33500) may be added to any gasoline left in the tank to minimize gum deposits and acids. If the tank is almost empty, mix stabilizer with fresh gasoline in a separate container and add some to the tank. **ALWAYS FOLLOW INSTRUCTIONS ON STABILIZER CONTAINER. THEN RUN ENGINE AT LEAST 10 MINUTES AFTER STABILIZER IS ADDED TO ALLOW MIXTURE TO REACH CARBURETOR. STORE SNOW THROWER IN A SAFE PLACE. SEE WARNING ABOVE.**

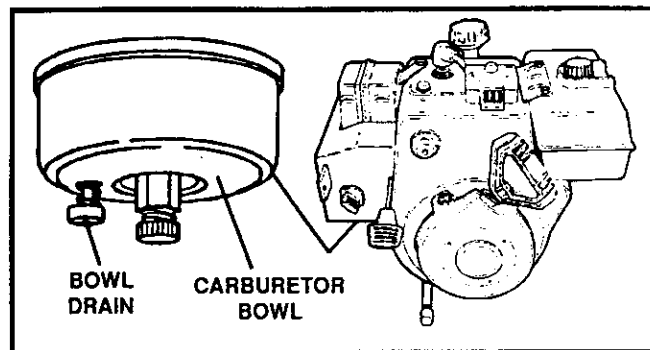

FIG. 1

You can keep your engine in good operating condition during storage by:

- Changing oil (See Customer Responsibilities section in this manual).
- Lubricating the piston/cylinder area. This can be done by first removing the spark plug and squirting a few drops of clean engine oil into the spark plug hole. Then cover the spark plug hole with a rag to absorb oil spray. Next, rotate the engine by pulling the starter rope fully out two or three times. Finally, reinstall spark plug and attach spark plug wire.

## OTHER

- If possible, store your snow thrower indoors and cover it to give protection from dust and dirt.
- If the machine must be stored outdoors, block up the snow thrower to be sure the entire machine is off the ground.
- Cover the snow thrower with a suitable protective cover that does not retain moisture. Do not use plastic.

**IMPORTANT:** NEVER COVER SNOW THROWER WHILE ENGINE AND EXHAUST AREAS ARE STILL WARM.

# TROUBLE SHOOTING POINTS

TROUBLE	CAUSE	CORRECTION
Difficult starting	Defective spark plug Water or dirt in fuel system	Replace defective plug. Use carburetor bowl drain to flush and refill with fresh fuel.
Engine runs erratically	Blocked fuel line or low on fuel	Clean fuel line; check fuel supply; add fresh fuel (gasoline/oil mixture if 2 cycle engine).
Engine stalls	Unit running on CHOKE	Set choke lever to RUN position.
Engine runs erratically; Loss of power	Water or dirt in fuel system  Carburetor out of adjustment	Use carburetor bowl drain to flush and refill with fresh fuel.  Adjust carburetor.
Excessive vibration	Loose parts; damaged impeller	Stop engine immediately and disconnect spark plug wire. Tighten all bolts and make all necessary repairs. If vibration continues, have the unit serviced by a competent repairman.
Unit fails to propel itself	Drive belt loose or damaged  Incorrect adjustment of traction drive cable  Worn or damaged friction wheel	Replace drive belt.  Adjust traction drive cable.  Replace friction wheel.
Unit fails to discharge snow	Auger drive belt loose or damaged  Auger control cable not adjusted correctly  Shear bolt broken  Discharge chute clogged  Foreign object lodged in auger	Adjust auger drive belt; replace if damaged.  Adjust auger control cable.  Replace shear bolt.  Stop engine immediately and disconnect spark plug wire. Clean discharge chute and inside of auger housing.  Stop engine immediately and disconnect spark plug wire. Remove object from auger.
Headlight does not work	Loose wire connection  Bulb burned out	Tighten connection.  Replace headlight bulb.